

---

**Single Chip IEEE 802.11 b/g/n Link Controller SOC**

---

**PRELIMINARY DATASHEET**

---

**Description**

---

The Atmel® WILC1000 is a single chip IEEE® 802.11 b/g/n IoT (Internet of Things) Link Controller SoC. The WILC1000 most advanced mode is a single stream 1x1 802.11n mode providing up to 72Mbps PHY throughput. The WILC1000 features fully integrated Power Amplifier, LNA, Switch and Power Management. Implemented in 65nm CMOS technology, the WILC1000 offers very low power consumption while simultaneously providing high performance and optimized bill of material.

The WILC1000 supports 2, 3, and 4 wire Bluetooth coexistence protocols. The WILC1000 provides multiple peripheral interfaces including UART, SPI, I2C, and SDIO. The only external clock source needed for the WILC1000 is a high-speed crystal or oscillator with a wide variety of reference clock frequencies supported (between 12 - 50MHz). The WILC1000 is available in both QFN and Wafer Level Chip Scale Package (WLCSP) packaging.

---

**Features**

---

- IEEE 802.11 b/g/n RF/PH/MAC SOC
- IEEE 802.11 b/g/n (1x1) for up to 72Mbps
- Single spatial stream in 2.5Ghz RF band
- Integrated PA and T/R Switch
- Superior Sensitivity and Range via advanced PHY signal processing
- Advanced Equalization and Channel Estimation
- Advanced Carrier and Timing Synchronization
- Wi-Fi Direct and Soft-AP support
- Supports IEEE 802.11 WEP, WPA, WPA2 Security
- Supports China WAPI security
- Superior MAC throughput via hardware accelerated two-level A-MSDU/A-MPDU frame aggregation and block acknowledgement
- On-chip memory management engine to reduce host load
- SPI and SDIO host interfaces
- 2/3/4-wire Bluetooth coexistence interface

## 1. Ordering Information

Ordering code	Package <sup>(1)</sup>	Description
ATWILC1000A-MU-T	5x5 QFN	Single 802.11.b/g/n Chip
ATWILC1000-MR110PA	22 X 15mm	Certified module with ATWILC1000A-MU chip and PCB antenna
ATWILC1000-SDPRO		ATWILC1000-MR110PA mounted on SD adapter card

Note: 1. The QFN package is a qualified Green Package.

## 2. Package Information

Table 2-1. WILC1000 QFN Package Information<sup>(1)</sup>

Parameter	Value	Units	Tolerance
Package Size	5 x 5	mm	± 0.1mm
QFN Pad Count	40		
Total Thickness	0.85	mm	± 0.05mm
QFN Pad Pitch	0.4	mm	
Pad Width	0.2	mm	
Exposed Pad Size	3.7 x 3.7	mm	

Note: 1. For the details, see ["Package Drawing" on page 24](#)

### 3. Block Diagram

Figure 3-1. WILC1000 Block Diagram

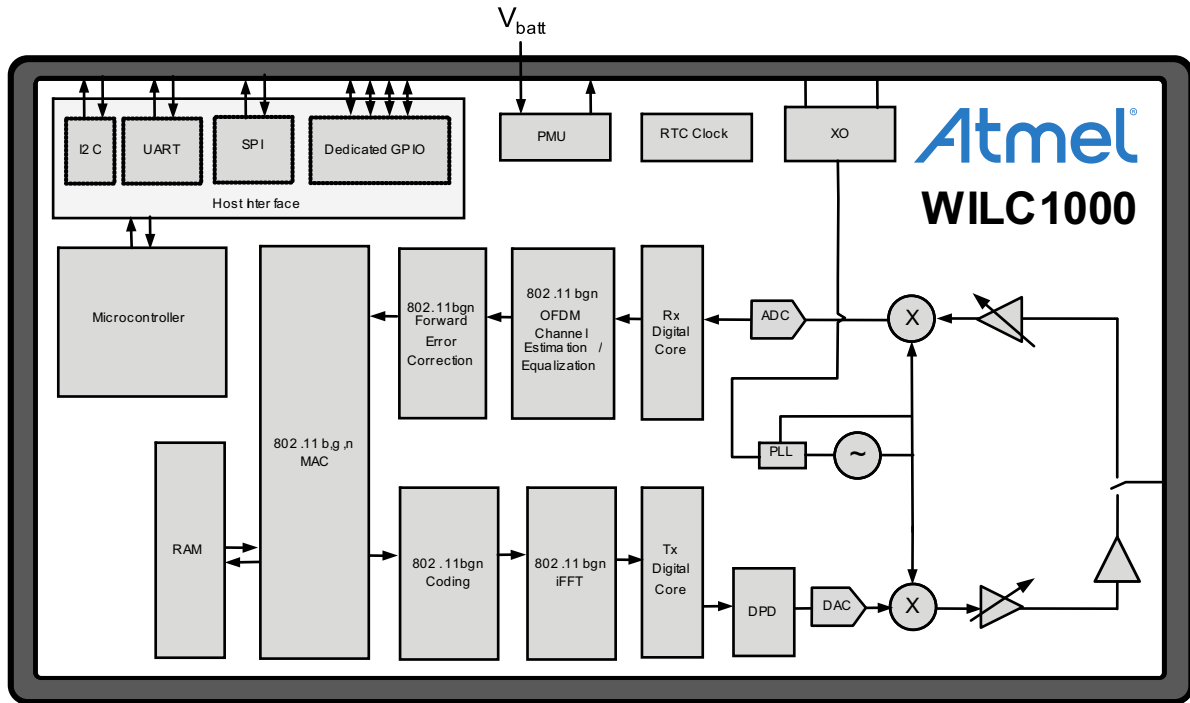

## 4. Pinout

The Atmel WILC1000 is offered in an exposed pad 40L, QFN package. The package has an exposed paddle that must be connected to the system board ground.

**Table 4-1. WILC1000 QFN Pin Connectivity**

Pin #	Pin Name	Pull up/down	Description
1	TP_P	None	Test Pin / Customer No Connect
2	VDD_RF	None	Tuner 1.2V RF Supply
3	RFIOP	None	Pos RF Differential I/O
4	RFION	None	Neg RF Differential I/O
5	PALDO_OUT	None	N/C. For internal use only
6	VDD_BATT	None	Battery Supply for PA LDO
7	VDD_AMS	None	1.2V Analog / Mixed Signal Supply
8	EFUSE_VDDQ	None	NC on customer board
9	SDIO_SPI_CFG	None	Tie to 1 for SPI, 0 for SDIO
10	GPIO0/HOST_WAKE	Programmable Pull-Up	GPIO0 / SLEEP Mode Control
11	GPIO2/IRQN	Programmable Pull-Up	GPIO2 / Device Interrupt
12	SD_DAT3	Programmable Pull-Up	SDIO Data3
13	SD_DAT2/SPI_RXD	Programmable Pull-Up	SDIO Data2 / SPI Data Rx
14	VDDC	None	1.2V Core Power Supply
15	VDDIO	None	I/O Power Supply
16	SD_DAT1/SPI_SSN	Programmable Pull-Up	SDIO Data1 / SPI Slave Select
17	SD_DAT0/SPI_TXD	Programmable Pull-Up	SDIO Data0 / SPI Data Tx
18	SD_CMD/SPI_SCK	Programmable Pull-Up	SDIO Command / SPI Clock
19	SD_CLK	Programmable Pull-Up	SDIO Clock
20	VBATT_BUCK	None	Battery Supply for DC/DC Converter
21	VSW	None	1.2V Power from DC/DC Converter
22	VREG_BUCK	None	Feeds VSW Back to DC/DC Converter
23	CHIP_EN	None	PMU Enable
24	GPIO1/RTC_CLK	Programmable Pull-Down	GPIO1 / 32kHz Clock Input
25	TEST_MODE	None	Test Mode - Customer Tie to GND
26	VDDIO	None	I/O Power Supply
27	VDDC	None	1.2V Core Power Supply
28	GPIO3	Programmable Pull-Up	GPIO3 / SPI_SCK_Flash
29	GPIO4	Programmable Pull-Up	GPIO4 / SPI_SSN_Flash

**Table 4-1. WILC1000 QFN Pin Connectivity (Continued)**

Pin #	Pin Name	Pull up/down	Description
30	GPIO5	Programmable Pull-Down	GPIO5 / SPI_TXD_Flash
31	GPIO6	Programmable Pull-Up	GPIO6 / SPI_RXD_Flash
32	I2C_SCL	Programmable Pull-Up	I2C Slave Clock
33	I2C_SDA	Programmable Pull-Up	I2C Slave Data
34	RESETN	None	Active-Low Hard Reset
35	XO_N	None	Crystal Oscillator N
36	XO_P	None	Crystal Oscillator P
37	VDD_SXDIG	None	1.2V SX Power Supply
38	VDD_VCO	None	1.2V VCO Power Supply
39	VDDA_IO	None	Tuner VDDIO Supply
40	TPN	None	Test Pin / Customer No Connect
41	PADDLE VSS	None	Connect to System Board Ground

## 5. Power Management

### 5.1 Power Architecture

The Atmel WILC1000 device uses an innovative power architecture to eliminate the need for external regulators and reduce the number of off-chip components. The architecture is shown in Figure 5-1.

The Power Management Unit (PMU) has a DC/DC Converter that converts VBATT to the 1.2V supply used by the digital and RF/AMS blocks. The PA and eFuse are supplied by dedicated LDOs, and the VCO is supplied by a separate LDO structure.

The power connections in Figure 5-1 provide a conceptual framework for understanding the WILC1000 power architecture. Reference designs will be provided to demonstrate how to properly connect the supplies, including proper isolation of the supplies used by the digital and RF/AMS blocks.

Figure 5-1. WILC1000 Power Architecture

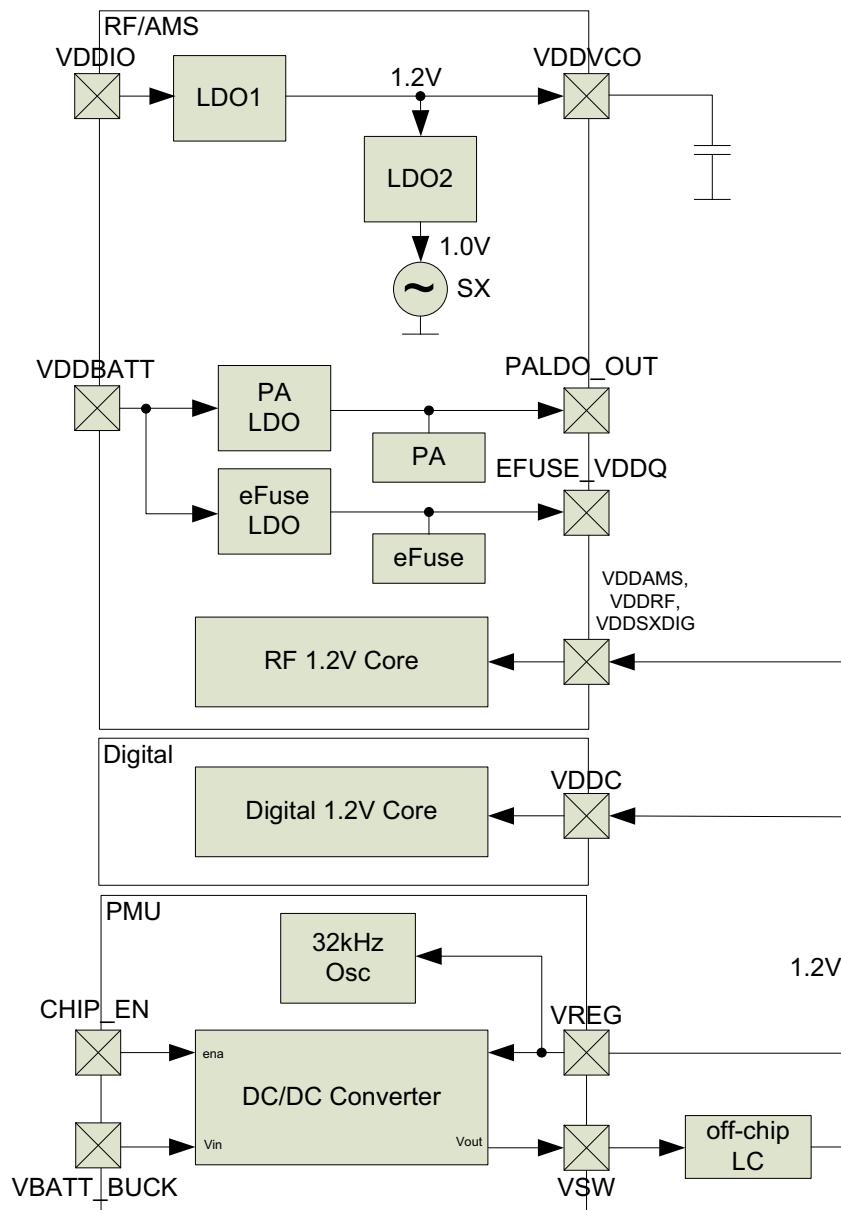

## 5.2 Power Consumption

### 5.2.1 Description of Device States

Atmel WILC1000 device has several Device States:

- **ON\_Transmit** – Device is actively transmitting an 802.11 signal
- **ON\_Receive** – Device is actively receiving an 802.11 signal
- **ON\_Doze** – Device is on but is neither transmitting nor receiving
- **SLEEP** – Device is asleep with 1.2V supply off
- **Power\_Off** – Device is powered off; VDD\_1P2 and VDDIO are off

### 5.2.2 Controlling the Device States

Table 5-1 shows how to switch between the device states using the following:

- **CHI\_EN** – Device pin (pin #23) used to enable DC/DC Converter
- **VDDIO** – I/O supply voltage from external supply

Table 5-1. WILC1000 Device State Control

Device State	CHIP_EN	VDDIO	Remark	Power Consumption
ON_Transmit	VDDIO	On	Transmitting	172mA @3.3V (18dBm) 149mA @2.5V (14dBm) 117mA @2.0V (10dBm)
ON_Receive	VDDIO	On	Receiving	70mA @3.3V (-90dBm) 65mA @3.3V (-87dBm)
ON_Doze	VDDIO	On	Idle <sup>(1)</sup>	< 1mA
SLEEP	GND	On		< 4µA

Note: 1. The device is Idle in ON\_Doze state during Passive Scan waiting for the Beacon Signal

### 5.2.3 Restrictions for Power\_Off State

When the Atmel WILC1000 is in the Device State Power\_Off, there is no power supplied to the device, i.e., the DC/DC Converter output and VDDIO are both off (at ground potential). In this case, a voltage cannot be applied to the WILC1000 pins because each pin contains an ESD diode from the pin to supply. This diode will turn on when voltage higher than one diode-drop is supplied to the pin.

If a voltage must be applied to the signal pads while the chip is in a low power state, the VDDIO supply must be on, so the SLEEP state must be used.

Similarly, to prevent the pin-to-ground diode from turning on, do not apply a voltage that is more than one diode-drop below ground to any pin.

## **6. CPU and Memory Subsystem**

### **6.1 Processor**

The Atmel WILC1000 device has a Cortus APS3 32-bit processor with a JTAG debug interface. This processor performs many of the MAC functions, including but not limited to association, authentication, power management, security key management, and MSDU aggregation/de-aggregation. In addition, the processor provides flexibility for various modes of operation, such as STA and AP modes.

### **6.2 Memory Subsystem**

The APS3 core uses a small boot ROM along with a 128KB instruction RAM and a 64KB data RAM. In addition, the device uses a 128KB shared memory which allows the APS3 core to perform various data management tasks on the TX and RX data packets.

### **6.3 Non-Volatile Memory**

The Atmel WILC1000 device has 256 bits of non-volatile memory (NVM) that can be read by the CPU after device reset. This non-volatile one-time-programmable (OTP) memory can be used to store customer-specific parameters, such as the MAC address, along with calibration information, such as TX power calibration tables.



## 7. Clocking

### 7.1 Crystal Oscillator

Table 7-1. WILC1000 Crystal Oscillator Parameters

Parameter	Min	Typical	Max	Units
Crystal Resonant Frequency	12		32	MHz
Crystal Equivalent Series Resistance		50	150	$\Omega$
Stability	-100		100	ppm

The block diagram in Figure 7-1(a) shows how the internal Crystal Oscillator (XO) is connected to the external crystal. The XO has 5pF internal capacitance on each terminal XO\_P and XO\_N. To bypass the crystal oscillator with an external reference, an external signal capable of driving 5pF can be applied to the XO\_N terminal as shown Figure 7-1(b).

Figure 7-1. WILC1000 XO connections to crystal when (a) the crystal oscillator is used, and (b) the crystal oscillator is bypassed

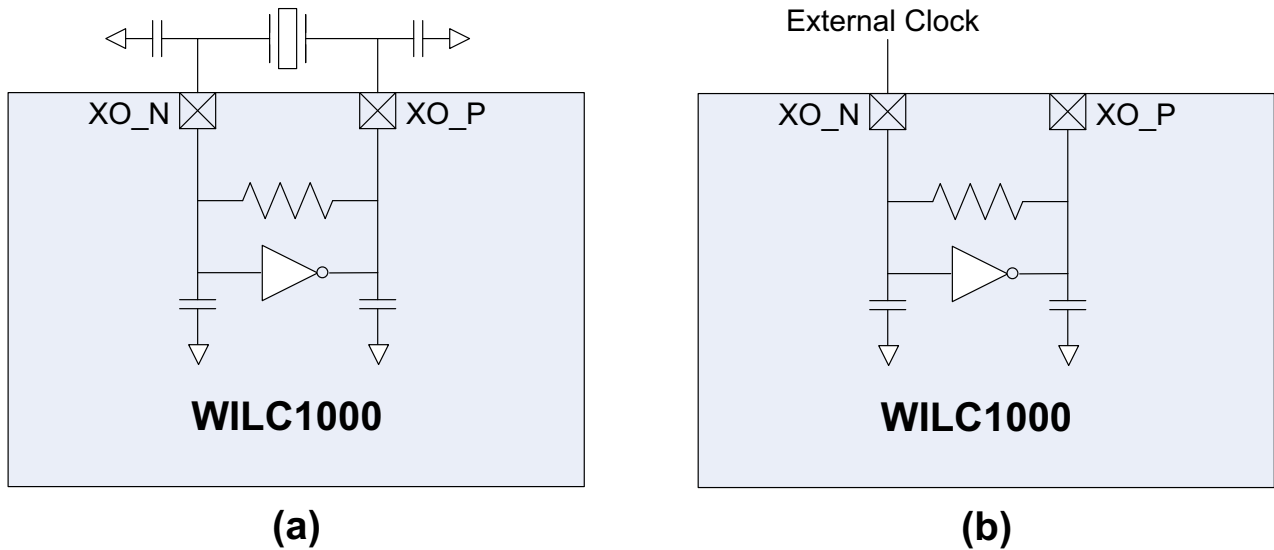

Table 7-2. WILC1000 Bypass Clock Specification

Parameter	Conditions	Min	Max	Units	Comments
Oscillator frequency		12	32	MHz	Must be able to drive 5pF load @ desired frequency
Voltage swing		0.5	1.8	Vpp	Must be AC coupled
Stability		-100	+100	ppm	
Phase Noise	@ 1KHz Offset		-130	dBc/Hz	
Jitter (RMS)			<1psec		Based on integrated phase noise spectrum from 1kHz to 1MHz

## 7.2 Low Power Oscillator

Atmel WILC1000 device provides an internally-generated 32kHz clock to provide timing information for various sleep functions. In addition, WILC1000 allows for an external 32kHz clock to be provided through Pin 24. Software selects whether the internal clock or external clock is used.

## 8. WLAN Subsystem

The WLAN subsystem is composed by the Media Access Controller (MAC) and the Physical Layer (PHY). The following two subsections describe the MAC and PHY in detail.

### 8.1 MAC

#### 8.1.1 Features

The Atmel WILC1000 IEEE802.11 MAC supports the following functions:

- IEEE 802.11b/g/n
- IEEE 802.11e WMM QoS EDCA/HCCA/PCF multiple access categories traffic scheduling
- Advanced IEEE 802.11n features:
  - Transmission and reception of aggregated MPDUs (A-MPDU)
  - Transmission and reception of aggregated MSDUs (A-MSDU)
  - Immediate Block Acknowledgement
  - Reduced Interframe Spacing (RIFS)
- Support for IEEE802.11i and WPA security with key management
  - WEP 64/128
  - WPA-TKIP
  - 128-bit WPA2 CCMP (AES)
- Support for WAPI security
- Advanced power management
  - Standard 802.11 Power Save Mode
  - Wi-Fi Alliance WMM-PS (U-APSD)
  - PSMP
- RTS-CTS and CTS-self support
- Supports either STA or AP mode in the infrastructure basic service set mode
- Supports independent basic service set (IBSS)
- Built-in programmable processor for future enhancement and standards evolution
- Auto-rate control
- MIB management

#### 8.1.2 Description

The Atmel WILC1000 MAC is designed to operate at low power while providing high data throughput. The IEEE 802.11 MAC functions are implemented with a combination of dedicated datapath engines, hardwired control logic, and a low-power, high-efficiency microprocessor. The combination of dedicated logic with a programmable processor provides optimal power efficiency and real-time response while providing the flexibility to accommodate evolving standards and future feature enhancements.

Dedicated datapath engines are used to implement data path functions with heavy computational. For example, an FCS engine checks the CRC of the transmitting and receiving packets, and a cipher engine performs all the required encryption and decryption operations for the WEP, WPA-TKIP, WPA2 CCMP-AES, and WAPI security requirements.

Control functions which have real-time requirements are implemented using hardwired control logic modules. These logic modules offer real-time response while maintaining configurability via the processor. Examples of hardwired control logic modules are the channel access control module (implements EDCA/HCCA, Beacon TX control, interframe spacing, etc.), protocol timer module (responsible for the Network Access Vector, back-off timing, timing synchronization function, and slot management), MPDU handling module, aggregation/de-aggregation module, block-ack controller (implements the protocol requirements for burst block communication), and TX/RX control FSMs (coordinate data movement between PHY-MAC interface, cipher engine, and the DMA interface to the TX/RX FIFOs).

The MAC functions implemented solely in software on the microprocessor have the following characteristics:

- Functions with high memory requirements or complex data structures. Examples are association table management and power save queuing.
- Functions with low computational load or without critical real-time requirements. Examples are authentication and association.
- Functions which need flexibility and upgradeability. Examples are beacon frame processing and QoS scheduling.

## 8.2 PHY

### 8.2.1 Features

The Atmel WILC1000 IEEE802.11 PHY supports the following functions:

- Single antenna 1x1 stream in 20MHz channels
- Supports IEEE 802.11b DSSS-CCK modulation: 1, 2, 5.5, 11Mbps
- Supports IEEE 802.11g OFDM modulation: 6, 9, 12, 18, 24, 36, 48, 54Mbps
- Supports IEEE 802.11n HT modulations MCS0-7, 20MHz, 800 and 400ns guard interval: 6.5, 7.2, 13.0, 14.4, 19.5, 21.7, 26.0, 28.9, 39.0, 43.3, 52.0, 57.8, 58.5, 65.0, 72.2Mbps
- IEEE 802.11n mixed mode operation
- Per packet TX power control
- Advanced channel estimation/equalization, automatic gain control, CCA, carrier/symbol recovery, and frame detection

### 8.2.2 Description

The Atmel WILC1000 PHY is designed to achieve reliable and power-efficient physical layer communication specified by IEEE 802.11 b/g/n in single stream mode with 20MHz bandwidth. Advanced algorithms have been employed to achieve maximum throughput in a real world communication environment with impairments and interference. The PHY implements all the required functions such as FFT, filtering, FEC (Viterbi decoder), frequency and timing acquisition and tracking, channel estimation and equalization, carrier sensing and clear channel assessment, as well as the automatic gain control.

## 8.3 Radio

### 8.3.1 Receiver Performance

Table 8-1. WILC1000 Receiver Performance

Parameter	Description	Min	Typical	Max	Unit
Frequency		2,412		2,484	MHz
Sensitivity 802.11b	1Mbps DSS		-98.2		dBm
	2Mbps DSS		-94.7		dBm
	5.5Mbps DSS		-93.0		dBm
	11Mbps DSS		-89.0		dBm
Sensitivity 802.11g	6Mbps OFDM		-91.0		dBm
	9Mbps OFDM		-90.0		dBm
	12Mbps OFDM		-88.5		dBm
	18Mbps OFDM		-86.5		dBm
	24Mbps OFDM		-84.0		dBm
	36Mbps OFDM		-80.5		dBm
	48Mbps OFDM		-77.0		dBm
	54Mbps OFDM		-75.0		dBm
Sensitivity 802.11n (BW = 20MHz)	MCS 0		-89.5		dBm
	MCS 1		-87.5		dBm
	MCS 2		-85.0		dBm
	MCS 3		-82.5		dBm
	MCS 4		-80.0		dBm
	MCS 5		-75.5		dBm
	MCS 6		-73.5		dBm
	MCS 7		-72.0		dBm
Maximum Receive Signal Level	1-11Mbps DSS	-10	0		dBm
	6-54Mbps OFDM	-10	0		dBm
	MCS 0 - 7	-10	0		dBm

**Table 8-1. WILC1000 Receiver Performance (Continued)**

Parameter	Description	Min	Typical	Max	Unit
Adjacent Channel Rejection	1Mbps DSS (30MHz offset)		50		dB
	11Mbps DSS (30MHz offset)		43		dB
	6Mbps OFDM (25MHz offset)		40		dB
	54Mbps OFDM (25MHz offset)		25		dB
	MCS 0 - 20MHz BW (25MHz offset)		40		dB
	MCS 7 - 20MHz BW (25MHz offset)		20		dB
Cellular Blocker Immunity	776-794MHz CDMA		-14		dBm
	824-849MHz GSM		-10		dBm
	880-915MHz GSM		-10		dBm
	1710-1785MHz GSM		-15		dBm
	1850-1910MHz GSM		-15		dBm
	1850-1910MHz WCDMA		-24		dBm
	1920-1980MHz WCDMA		-24		dBm

### 8.3.2 Transmitter Performance

**Table 8-2. WILC1000 Transmitter Performance**

Parameter	Description	Min	Typical	Max	Unit
<b>Frequency</b>		<b>2,412</b>		<b>2,484</b>	<b>MHz</b>
Output Power	802.11b DSSS 1Mbps		20.6 <sup>(1)</sup>		dBm
	802.11b DSSS 11Mbps		20.6 <sup>(1)</sup>		dBm
	802.11g OFDM 6Mbps		20.5 <sup>(1)</sup>		dBm
	802.11g OFDM 54Mbps		17.8 <sup>(1)</sup>		dBm
	802.11n HT20 MCS 0		18.8 <sup>(1)</sup>		dBm
	802.11n HT20 MCS 7		15.3 <sup>(1)</sup>		dBm
Tx Power Accuracy			±1.5 <sup>(2)</sup>		dB
Carrier Suppression			30.0		dBc

**Table 8-2. WILC1000 Transmitter Performance (Continued)**

Parameter	Description	Min	Typical	Max	Unit
Sensitivity 802.11g	76-108		-125		dBm/Hz
	776-794		-125		dBm/Hz
	869-960		-125		dBm/Hz
	925-960		-125		dBm/Hz
	1570-1580		-125		dBm/Hz
	1805-1880		-125		dBm/Hz
	1930-1990		-125		dBm/Hz
	2110-2170		-125		dBm/Hz
Harmonic Output Power	2 <sup>nd</sup>		-33		dBm/MHz
	3 <sup>rd</sup>		-38		dBm/MHz

Notes: 1. Measured at 802.11 spec compliant EVM / Spectral Mask  
 2. Without calibration

### 8.3.3 Calibration

Atmel WILC1000 device does not require any external calibration to meet the specifications shown in this document. The WILC1000 does however contain nonvolatile memory for customer's optional use.

- Frequency Compensation - Improve frequency accuracy of main system clock based on external crystal
- Power control - Improve output power tolerance beyond limits specified in this document
- MAC address programming

## 9. External Interfaces

Atmel WILC1000 external interfaces include I<sup>2</sup>C for control, SPI and SDIO for control and data transfer, seven General Purpose Input / Output (GPIO) pins, and a Wi-Fi / Bluetooth coexistence interface.

### 9.1 I<sup>2</sup>C Interface

#### 9.1.1 Overview

Atmel WILC1000 provides an I<sup>2</sup>C bus slave that allows the host processor to read or write any register in the chip. The WILC1000 supports I<sup>2</sup>C bus Version 2.1 - 2000.

The I<sup>2</sup>C interface, used primarily for control, is a two-wire serial interface consisting of a serial data line (SDA, Pin 33) and a serial clock (SCL, Pin 32). It responds to the seven bit address value 0x60. The WILC1000 I<sup>2</sup>C interface can operate in standard mode (with data rates up to 100Kb/s) and fast mode (with data rates up to 400Kb/s).

The I<sup>2</sup>C is a synchronous serial interface. The SDA line is a bidirectional signal and changes only while the SCL line is low, except for STOP, START, and RESTART conditions. The output drivers are open-drain to perform wire-AND functions on the bus. The maximum number of devices on the bus is limited by only the maximum capacitance specification of 400pF. Data is transmitted in byte packages.

For specific information, please refer to the Philips Specification entitled "The I<sup>2</sup>C -Bus Specification, Version 2.1".

#### 9.1.2 I<sup>2</sup>C Timing

The I<sup>2</sup>C is provided in [Figure 9-1](#) and in [Table on page 17](#).

**Figure 9-1. WILC1000 I<sup>2</sup>C Timing Diagram**

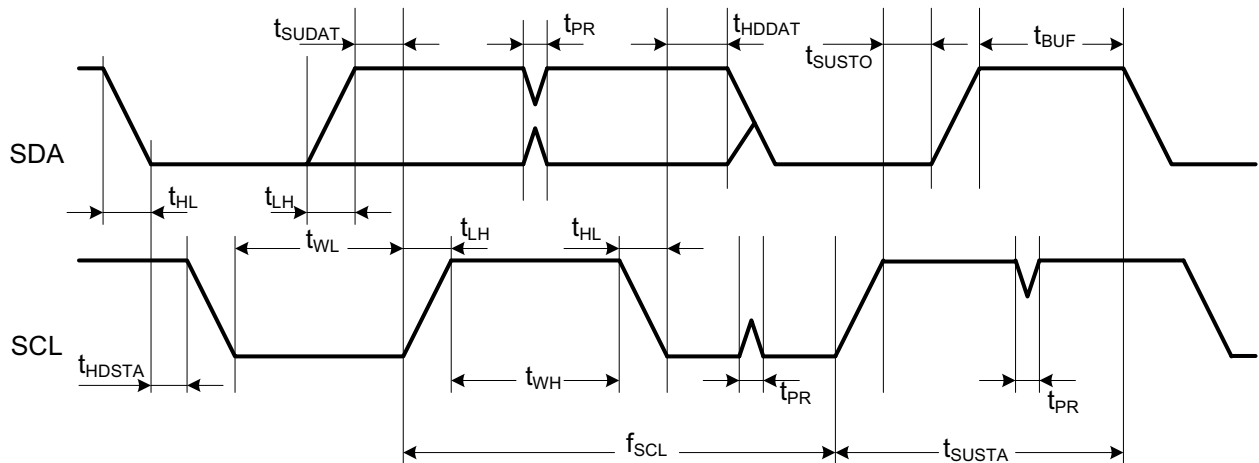



**Table 9-1. WILC1000 I<sup>2</sup>C Timing Parameters**

Parameter	Symbol	Min	Max	Units	Remarks
SCL clock frequency	f <sub>SCL</sub>	0	400	kHz	
SCL low pulse width	t <sub>WL</sub>	1.3		μs	
SCL high pulse width	t <sub>WH</sub>	0.6		μs	
SCL, SDA fall time	t <sub>HL</sub>		300	ns	
SCL, SDA rise time	t <sub>LH</sub>		300	ns	This is dictated by external components
START setup time	t <sub>SUSTA</sub>	0.6		μs	
START hold time	t <sub>HDSTA</sub>	0.6		μs	
SDA setup Time	t <sub>SUDAT</sub>	100		ns	
SDA hold time	t <sub>HDDAT</sub>	0		ns	Slave and Master default
		40		ns	Master programming option
STOP setup time	t <sub>SUSTO</sub>	0.6		μs	
Bus free time between STOP and START	t <sub>BUF</sub>	1.3		μs	
Glitch pulse reject	t <sub>PR</sub>	0	50	ns	

## 9.2 SPI Interface

### 9.2.1 Overview

Atmel WILC1000 device has a Serial Peripheral Interface (SPI) that operates as a SPI slave. The SPI interface can be used for control and for serial I/O of 802.11 data. The SPI pins are mapped as shown in Table 12. The SPI is a full-duplex slave-synchronous serial interface that is available immediately following reset when pin 9 (SDIO\_SPI\_CFG) is tied to VDDIO.

**Table 9-2. WILC1000 SPI Interface Pin Mapping**

Pin #	SPI Function
9	CFG: Must be tied to VDDIO
16	SSN: Active Low Slave Select
13	RXD: Serial Data Receive
18	SCK: Serial Clock
17	TXD: Serial Data Transmit

When the SPI is not selected, i.e., when SSN is high, the SPI interface will not interfere with data transfers between the serial-master and other serial-slave devices. When the serial slave is not selected, its transmitted data output is buffered, resulting in a high impedance drive onto the serial master receive line.

The SPI interface responds to a protocol that allows an external host to read or write any register in the chip as well as initiate DMA transfers.

## 9.2.2 SPI Timing

The SPI timing is provided in [Figure 9-2](#) and in [Table on page 18](#)

**Figure 9-2. WILC1000 SPI Timing Diagram**

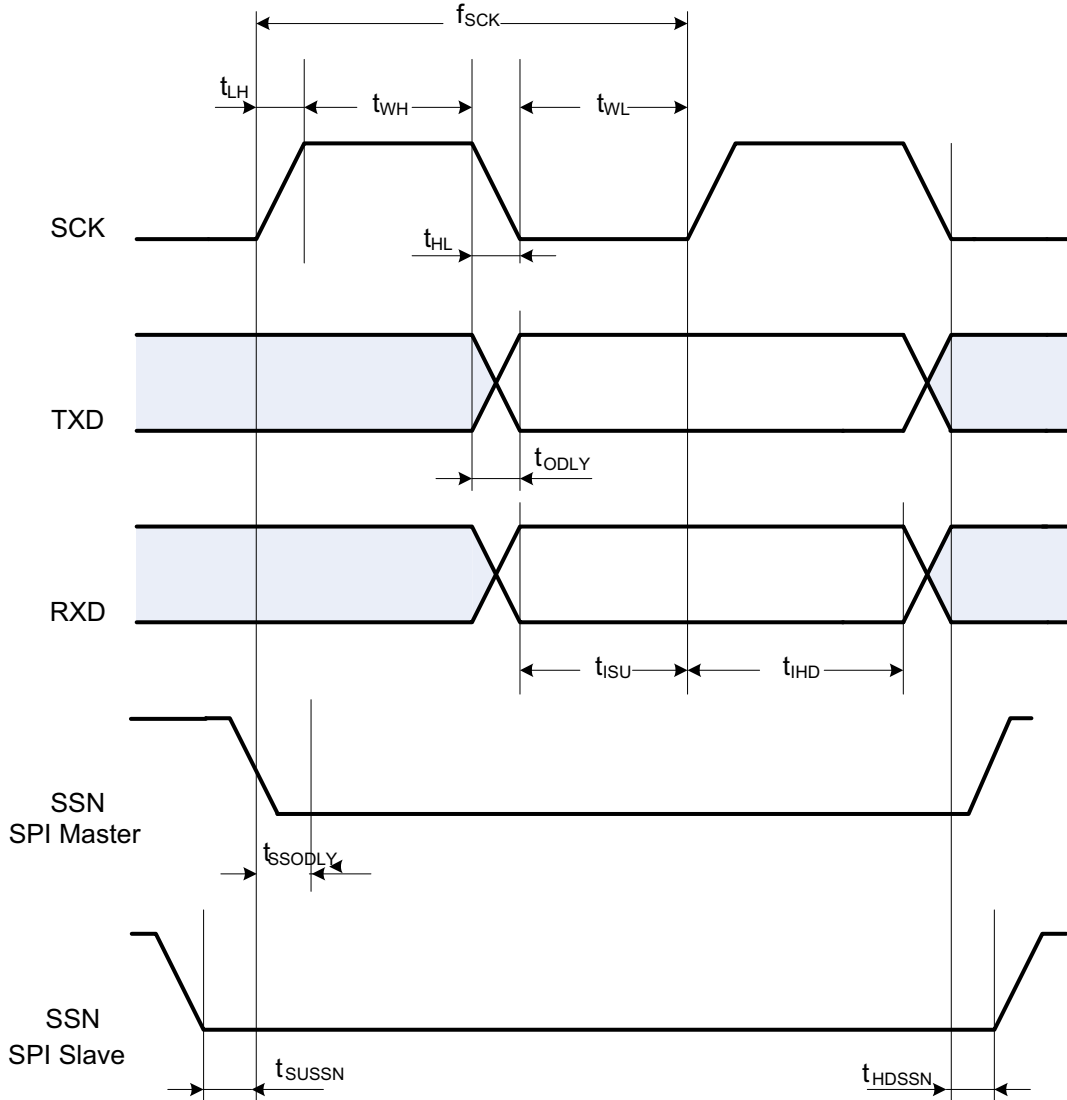

**Table 9-3. WILC1000 SPI Slave Timing Parameters**

Parameter	Symbol	Min	Max	Units
Clock input frequency	$f_{SCK}$		48	MHz
Clock low pulse width	$t_{WL}$	15		ns
Clock high pulse width	$t_{WH}$	15		ns
Clock rise time	$t_{LH}$		10	ns
Clock fall time	$t_{HL}$		10	ns
Input setup time	$t_{ISU}$	5		ns

**Table 9-3. WILC1000 SPI Slave Timing Parameters**

Parameter	Symbol	Min	Max	Units
Input hold time	$t_{IHD}$	5		ns
Output Delay	$t_{ODLY}$	0	20	ns
Slave select setup time	$t_{SUSSN}$	5		ns
Slave select hold time	$t_{HDSSN}$	5		ns

## 9.3 Wi-Fi / Bluetooth Coexistence

Atmel WILC1000 device supports 2-wire, 3-wire, and 4-wire WiFi/Bluetooth Coexistence algorithms. As shown in [Table 9-4](#), the 2-wire interface uses GPIO3 and GPIO4, the 3-wire interface uses GPIO3, GPIO4, and GPIO5, and the 4-wire interface uses GPIO3, GPIO4, GPIO5, and GPIO6.

**Table 9-4. WILC1000 Coexistence Pins**

Pin Name	Pin #	2-wire	3-wire	4-wire
GPIO3	28	Not used	Used	Used
GPIO4	29	Used	Used	Used
GPIO5	30	Used	Used	Used
GPIO6	31	Not used	Not used	Not used

## 9.4 SDIO Interface

### 9.4.1 Features

- Meets SDIO card specification version 2.0
- Host clock rate variable between 0 and 50MHz
- 1 bit/4-bit SD bus modes supported
- Allows card to interrupt host
- Responds to Direct read/write (IO52) and Extended read/write (IO53) transactions
- Supports Suspend/Resume operation

### 9.4.2 Description

The WILC1000 SDIO is a full speed interface. The interface supports the 1-bit/4-bit SD transfer mode at the clock range of 0-50MHz. The Host can use this interface to read and write from any register within the chip as well as configure the WILC1000 for data DMA. To use this interface, pin 9 (SDIO\_SPI\_CFG) must be grounded. The SDIO pins are mapped as shown in [Table](#) .

**Table 9-5. WILC1000 SDIO Interface Pin Mapping**

Pin #	SPI Function
9	CFG: Must be tied to ground
12	DAT3: Data 3
13	DAT2: Data 2

**Table 9-5. WILC1000 SDIO Interface Pin Mapping (Continued)**

Pin #	SPI Function
16	DAT1: Data 1
17	DAT0: Data 0
18	CMD: Command
19	CLK: Clock

When the SDIO card is inserted into an SDIO aware host, the detection of the card will be via the means described in SDIO specification. During the normal initialization and interrogation of the card by the host, the card will identify itself as an SDIO device. The host software will obtain the card information in a tuple (linked list) format and determine if that card's I/O function(s) are acceptable to activate. If the card is acceptable, it will be allowed to power up fully and start the I/O function(s) built into it.

The SD memory card communication is based on an advanced 9-pin interface (Clock, Command, 4 Data and 3 Power lines) designed to operate at maximum operating frequency of 50MHz.

### 9.4.3 SDIO Timing

**Figure 9-3. WILC1000 SDIO Timing Diagram**

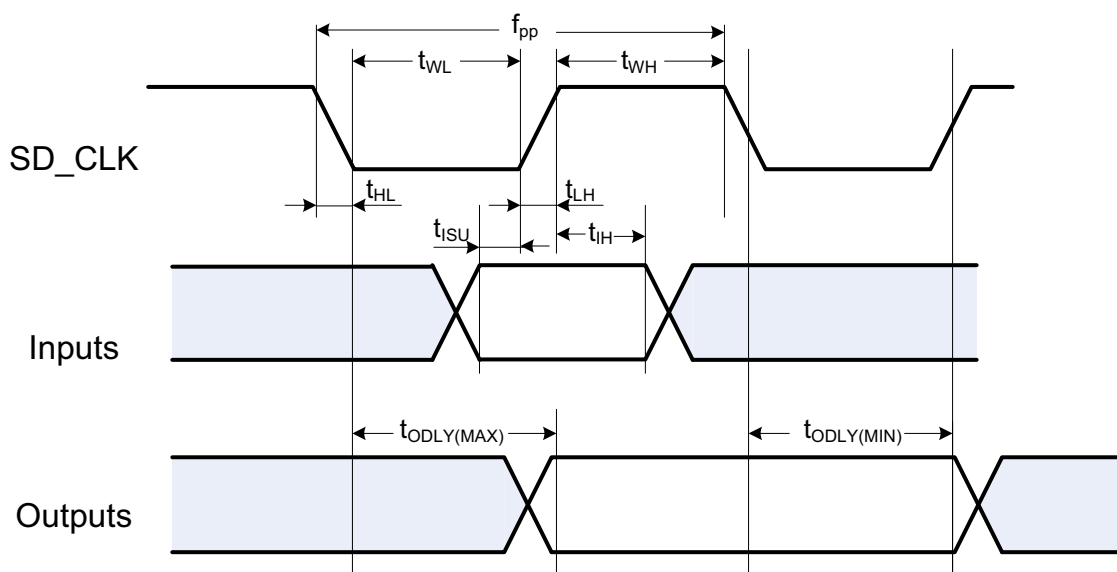

**Table 9-6. WILC1000 SDIO Timing Parameters**

Parameter	Symbol	Min	Max	Units
Clock input frequency	$f_{pp}$	0	50	MHz
Clock low pulse width	$t_{WL}$	10		ns
Clock high pulse width	$t_{WH}$	10		ns
Clock rise time	$t_{LH}$		10	ns
Clock fall time	$t_{HL}$		10	ns

**Table 9-6. WILC1000 SDIO Timing Parameters (Continued)**

Parameter	Symbol	Min	Max	Units
Input setup time	$t_{ISU}$	5		ns
Input hold time	$t_{IH}$	5		ns
Output Delay	$t_{ODLY}$	0	14	ns

## 9.5 GPIOs

Seven General Purpose Input / Output (GPIO) pins are available to allow for application specific functions. Each GPIO pin can be programmed as an input (the value of the pin can be read by the host or internal processor) or as an output (the output values can be programmed by the host or internal processor), where the default mode after power-up is input.

## 10. Electrical Characteristics

### 10.1 Absolute Maximum Ratings

Table 10-1. Absolute Maximum Ratings

Symbol	Parameter	Min	Max	Unit
VDD_1P2	1.2V supply voltage	-0.3	1.5	V
VDDIO	I/O supply voltage	-0.3	3.6	V
VBATT	Battery supply voltage	-0.3	6.0	V
V <sub>IN</sub>	Digital input voltage	-0.3	VDDIO+0.3 (up to 3.6)	V
V <sub>AIN</sub> <sup>(1)</sup>	Analog input voltage	-0.3		V
V <sub>ESDHBM</sub> <sup>(2)</sup>	ESD human body model	-1000, -2000	+1000, +2000	V
T <sub>A</sub>	Storage temperature	-65	150	°C
	Junction temperature		125	°C
	RF input power max		16	dBm

- Notes:
- V<sub>AIN</sub> is for the following analog pins: VDD\_RF, RFIO\_P, RFIO\_N, VDD\_AMS, XO\_N, XO\_P, VDD\_SXDIG, VDD\_VCO
  - For V<sub>ESDHBM</sub>, each pin is classified as Class1 or Class2
    - The Class1 pins are: TP\_P, VDD\_RF, RFIO\_P, RFIO\_N, PALDO\_OUT, VDD\_BATT, VDD\_AMS, EFUSE\_VDDQ, VBATT\_BUCK, VSW, VREG\_BUCK, CHIP\_EN, XO\_N, XO\_P, VDD\_SXDIG, VCC\_VCO, VDDA\_IO, TPN. All others are Class2 pins.
    - V<sub>ESDHBM</sub> is 1kV for Class1 pins. V<sub>ESDHBM</sub> is 2kV for Class2 pins.

### 10.2 Recommended Operating Conditions

Table 10-2. Recommended Operating Conditions

Symbol	Parameter	Min	Typical	Max	Unit
VDD_1P2	1.2V supply voltage	1.235	1.3	1.356	V
VDDIO <sub>L</sub>	I/O supply voltage low range	1.62	1.8	1.98	V
VDDIO <sub>M</sub>	I/O supply voltage mid range	2.25	2.50	2.75	V
VDDIO <sub>H</sub>	I/O supply voltage high range	3.00	3.30	3.60	V
VBATT	Battery supply voltage	2.5 <sup>(1)</sup>	3.6	4.2	V
	Operating temperature	-20		85	°C

- Note:
- The Atmel WILC1000 is functional across this range of voltages; however, optimal RF performance is guaranteed for VBATT in the range 3.0V < VBATT < 4.2V.

### 10.3 DC Characteristics

The [Table 10-3](#) provides the DC characteristics for the digital pads.

**Table 10-3. Recommended Operating Conditions**

VDDIO	Condition	Min	Max	Unit
VDDIO <sub>L</sub>	Input low voltage V <sub>IL</sub>	-0.30	0.63	V
	Input high voltage V <sub>IH</sub>	1.17	VDDIO+0.30	V
	Output low voltage V <sub>OL</sub>		0.45	V
	Output high voltage V <sub>OH</sub>	1.35		V
VDDIO <sub>M</sub>	Input low voltage V <sub>IL</sub>	-0.30	0.70	V
	Input high voltage V <sub>IH</sub>	1.70	VDDIO+0.30	V
	Output low voltage V <sub>OL</sub>		0.70	V
	Output high voltage V <sub>OH</sub>	1.70		V
VDDIO <sub>H</sub>	Input low voltage V <sub>IL</sub>	-0.30	0.80	V
	Input high voltage V <sub>IH</sub>	2.00	VDDIO+0.30 (up to 3.60)	V
	Output low voltage V <sub>OL</sub>		0.40	V
	Output high voltage V <sub>OH</sub>	2.40		V
All	Output loading		20	pF
All	Digital input load		6	pF

# 11. Package Drawing

## 11.1 40QFN 5x5

Figure 11-1. QFN Package Drawing

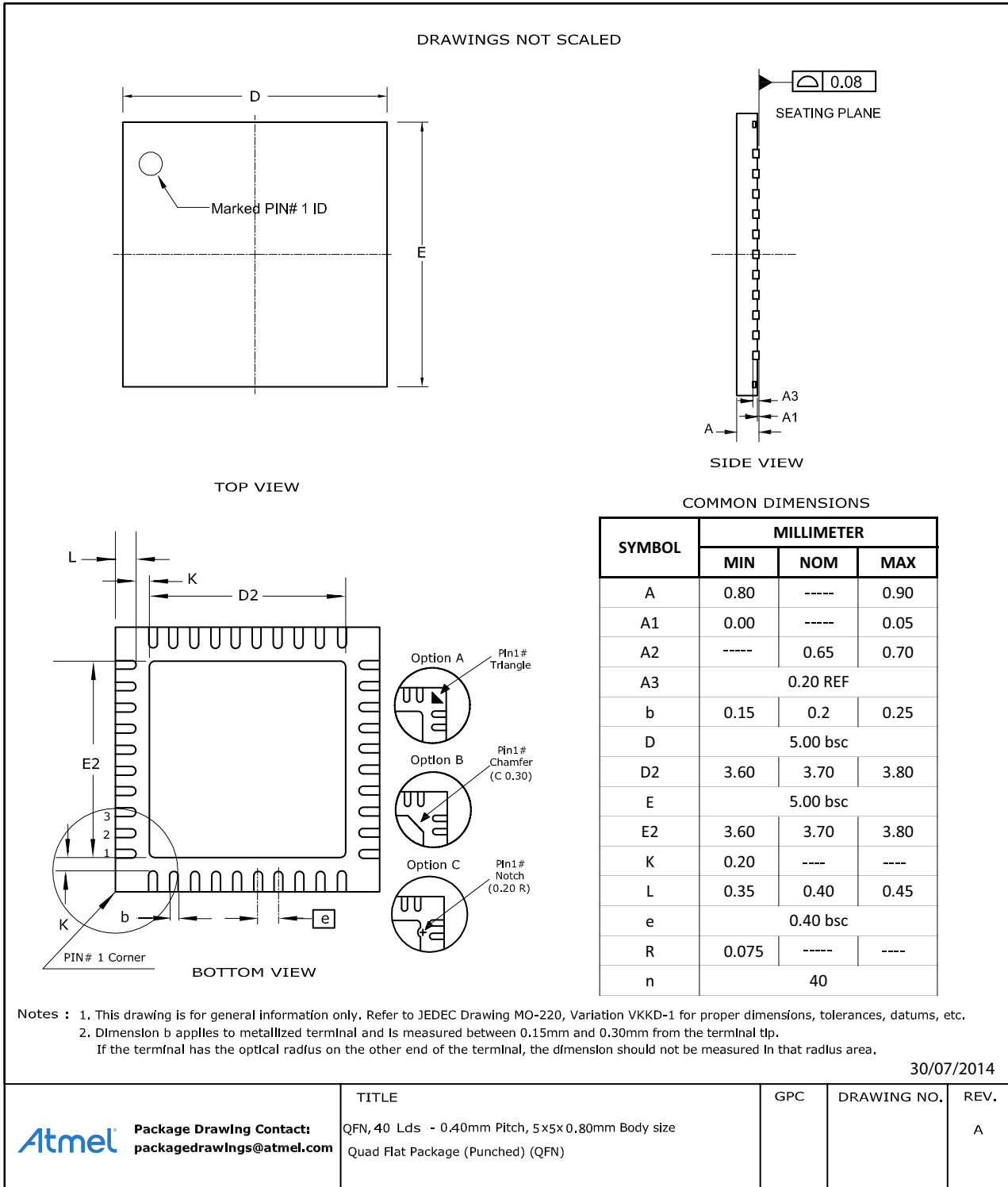



## 12. Technical Support and Resources

For technical support visit: <http://www.atmel.com/design-support>

## 13. Revision History

Doc. Rev.	Date	Comments
42351A	09/2014	Initial document release.

## Table of Contents

---

<b>Description</b> .....	1
<b>Features</b> .....	1
<b>1. Ordering Information</b> .....	2
<b>2. Package Information</b> .....	2
<b>3. Block Diagram</b> .....	3
<b>4. Pinout</b> .....	4
<b>5. Power Management</b> .....	6
5.1 Power Architecture .....	6
5.2 Power Consumption .....	7
<b>6. CPU and Memory Subsystem</b> .....	8
6.1 Processor .....	8
6.2 Memory Subsystem .....	8
6.3 Non-Volatile Memory .....	8
<b>7. Clocking</b> .....	9
7.1 Crystal Oscillator .....	9
7.2 Low Power Oscillator .....	10
<b>8. WLAN Subsystem</b> .....	11
8.1 MAC .....	11
8.2 PHY .....	12
8.3 Radio .....	13
<b>9. External Interfaces</b> .....	16
9.1 I2C Interface .....	16
9.2 SPI Interface .....	17
9.3 Wi-Fi / Bluetooth Coexistence .....	19
9.4 SDIO Interface .....	19
9.5 GPIOs .....	21
<b>10. Electrical Characteristics</b> .....	22
10.1 Absolute Maximum Ratings .....	22
10.2 Recommended Operating Conditions .....	22
10.3 DC Characteristics .....	23
<b>11. Package Drawing</b> .....	24
11.1 40QFN 5x5 .....	24
<b>12. Technical Support and Resources</b> .....	25
<b>13. Revision History</b> .....	26



**Atmel Corporation** 1600 Technology Drive, San Jose, CA 95110 USA T: (+1)(408) 441.0311 F: (+1)(408) 436.4200 | [www.atmel.com](http://www.atmel.com)

© 2014 Atmel Corporation. / Rev.: Atmel-42351A-ATWILC1000A-SmartConnect-Datasheet\_092014.

Atmel®, Atmel logo and combinations thereof, Enabling Unlimited Possibilities®, and others are registered trademarks or trademarks of Atmel Corporation in U.S. and other countries. Other terms and product names may be trademarks of others.

DISCLAIMER: The information in this document is provided in connection with Atmel products. No license, express or implied, by estoppel or otherwise, to any intellectual property right is granted by this document or in connection with the sale of Atmel products. EXCEPT AS SET FORTH IN THE ATMEL TERMS AND CONDITIONS OF SALES LOCATED ON THE ATMEL WEBSITE, ATMEL ASSUMES NO LIABILITY WHATSOEVER AND DISCLAIMS ANY EXPRESS, IMPLIED OR STATUTORY WARRANTY RELATING TO ITS PRODUCTS INCLUDING, BUT NOT LIMITED TO, THE IMPLIED WARRANTY OF MERCHANTABILITY, FITNESS FOR A PARTICULAR PURPOSE, OR NON-INFRINGEMENT. IN NO EVENT SHALL ATMEL BE LIABLE FOR ANY DIRECT, INDIRECT, CONSEQUENTIAL, PUNITIVE, SPECIAL OR INCIDENTAL DAMAGES (INCLUDING, WITHOUT LIMITATION, DAMAGES FOR LOSS AND PROFITS, BUSINESS INTERRUPTION, OR LOSS OF INFORMATION) ARISING OUT OF THE USE OR INABILITY TO USE THIS DOCUMENT, EVEN IF ATMEL HAS BEEN ADVISED OF THE POSSIBILITY OF SUCH DAMAGES. Atmel makes no representations or warranties with respect to the accuracy or completeness of the contents of this document and reserves the right to make changes to specifications and products descriptions at any time without notice. Atmel does not make any commitment to update the information contained herein. Unless specifically provided otherwise, Atmel products are not suitable for, and shall not be used in, automotive applications. Atmel products are not intended, authorized, or warranted for use as components in applications intended to support or sustain life.

SAFETY-CRITICAL, MILITARY, AND AUTOMOTIVE APPLICATIONS DISCLAIMER: Atmel products are not designed for and will not be used in connection with any applications where the failure of such products would reasonably be expected to result in significant personal injury or death ("Safety-Critical Applications") without an Atmel officer's specific written consent. Safety-Critical Applications include, without limitation, life support devices and systems, equipment or systems for the operation of nuclear facilities and weapons systems. Atmel products are not designed nor intended for use in military or aerospace applications or environments unless specifically designated by Atmel as military-grade. Atmel products are not designed nor intended for use in automotive applications unless specifically designated by Atmel as automotive-grade.