

晶采光電科技股份有限公司  
AMPIRE CO., LTD.

## SPECIFICATIONS FOR LCD MODULE

<b>CUSTOMER</b>	
<b>CUSTOMER PART NO.</b>	
<b>AMPIRE PART NO.</b>	<b>AO-162MGA00</b>
<b>APPROVED BY</b>	
<b>DATE</b>	

- Approved For Specifications  
 Approved For Specifications & Sample

**AMPIRE CO., LTD.**

**TOWER A, 4F, No.114, Sec. 1, HSIN-TAI 5th RD., HIS-CHIH,  
TAIPEI HSIEN, TAIWAN(R.O.C.)**

台北縣汐止鎮新台五路一段114號4樓(東方科學園區A棟)

**TEL:886-2-26967269, FAX:886-2-26967196 or 886-2-26967270**

APPROVED BY	CHECKED BY	ORGANIZED BY

## RECORD OF REVISION

Revision Date	Page	Contents	Editor
2004/5/5	-	New Release	Sam
2004/5/21	P.3	Modify the operating temp min to -10 degrees	
	P.4	Modify input voltage and logic supply current	
	P.7	Add the pin connections diagram	
	P.10	Modify ambient temperature to 20 degrees	
	P.12	Modify reliability low temperature operation	
2004/7/1	P.6	Modify the C1~C8 and C9~C16 Layout.	Kokai
2004/9/27		Modify the LCD data according the prototype	Kokai
		Modify the C1~C8 and C9~C16 Layout according the NT7651 ver1.0 data sheet.	
		Add LCD initial setting	
2004/9/30		Modify the pin length to 9.0min	kokai

## 1 FEATURES

- (1) Display format : 16 characters × 2 lines
- (2) Display type: STN Gray, Reflective, 6 o' clock view, Positive
- (3) Controller : NT7651H-BDT02
- (4) I<sup>2</sup>C Interface
- (5) Adopt COG Technology

## 2 MECHANICAL DATA

Parameter	Stand Value	Unit
Dot size	0.55(W) × 0.6(H)	mm
Dot pitch	0.6(W) × 0.65(H)	mm
Character size	2.95(W) × 5.15(H)	mm
Viewing area	61.0(W) × 13.7(H)	mm
Module size	65.0(W) × 27.7(H) × 2.7(T)	mm

## 3 ABSOLUTE MAXIMUM RATINGS

Parameter	Symbol	Min	Max	Unit	
Logic Circuit Supply Voltage	VDD-VSS	0	3.5	V	
LCD Driving Voltage	VLCD	0	6.5	V	
Input Voltage	VIN	VSS	VDD	V	
Normal temp. type	Operating Temp.	TOP	-10	50	°C
	Storage Temp.	TSTG	-20	70	°C

## 4 ELECTRO-OPTICAL CHARACTERISTICS

Parameter	Symbol	Condition	Min	Typ	Max	Unit	Note
----- Electronic Characteristics -----							
Logic Circuit Supply Voltage	VDD-VSS	--	--	3.3	--	V	
LCD Driving Voltage (STN)	VLCD	0 °C	4.5	4.6	4.7	V	
		25 °C	4.4	4.5	4.6		
		50 °C	4.3	4.4	4.5		
Input Voltage	VIH	--	0.8VDD	--	VDD	V	
	VIL	--	VSS	--	0.2VDD	V	
Logic Supply Current	IDD	VDD = 3.3V	--	0.2	--	mA	
----- Optical Characteristics (STN) -----							
Contrast	CR	25°C	--	5.2	--		Note 1
Rise Time	tr	25°C	--	120	180	ms	Note 2
Fall Time	tf	25°C	--	250	400	ms	
Viewing Angle Range	θ f	25°C & CR≥2	--	40	--	Deg.	Note 3
	θ b		--	35	--		
	θ l		--	35	--		
	θ r		--	35	--		
Frame Frequency	fF	25°C	--	64	--	Hz	

(NOTE 1) Contrast ratio :

CR = (Brightness in OFF state) / (Brightness in ON state)

( NOTE 2 ) Response time :

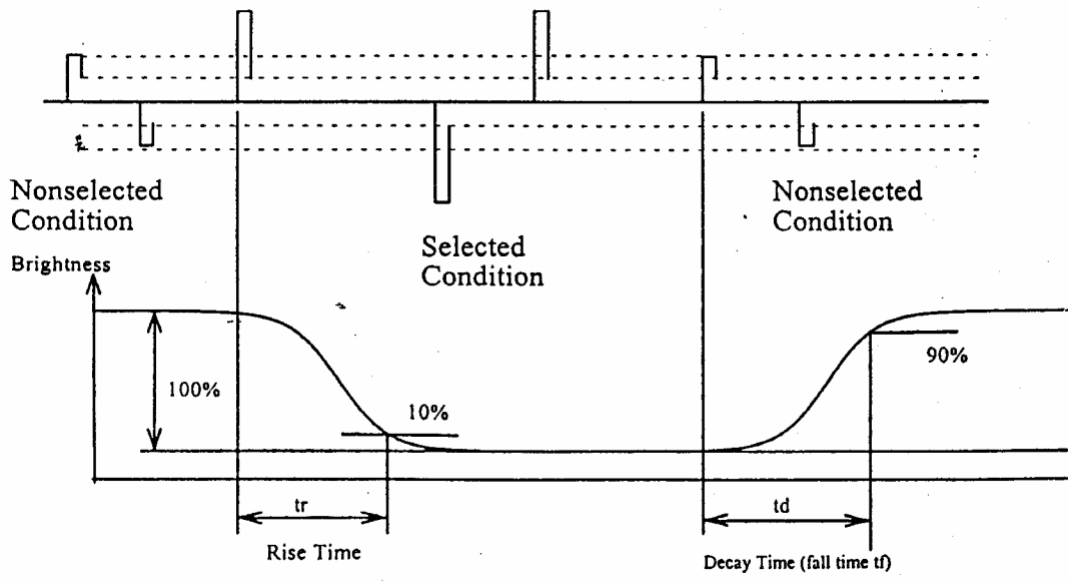

(NOTE 3) Viewing angle

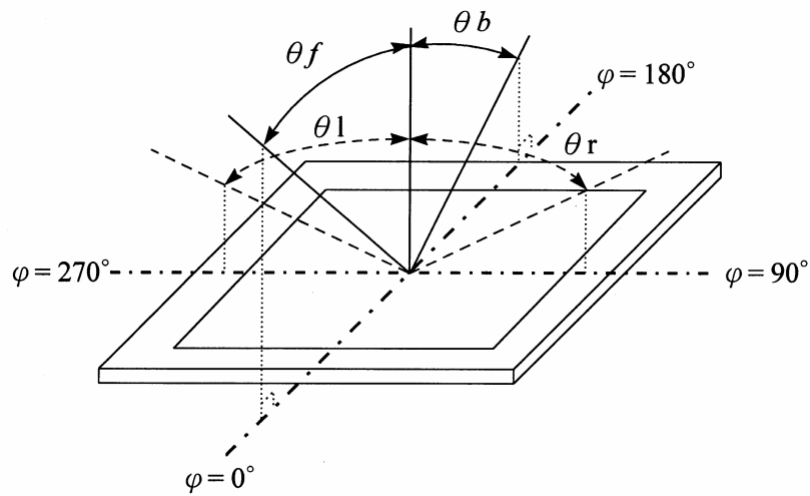

## 5 BLOCK DIAGRAM

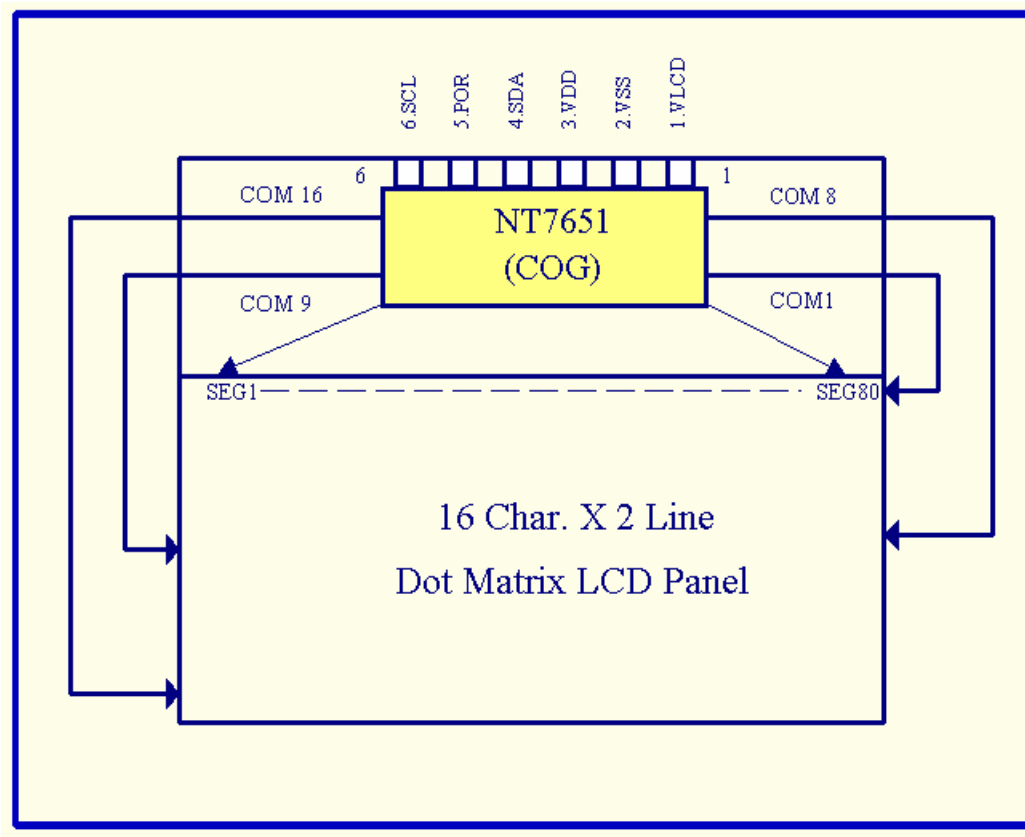

## 6 PIN CONNECTIONS

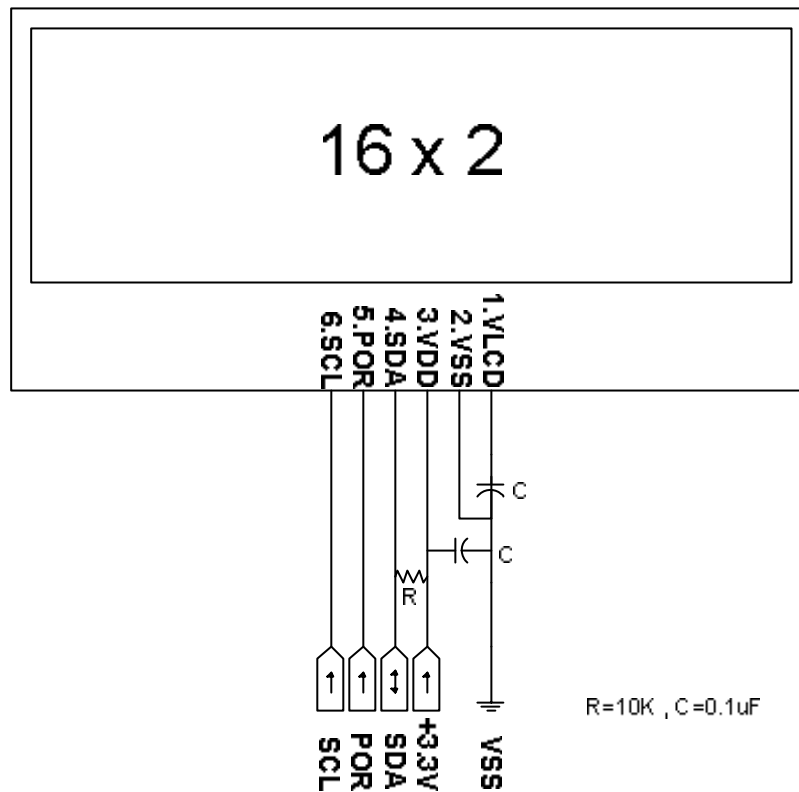

PIN NO.	SYMBOL	LEVEL	FUNCTION
1	VLCD	-	Internal Generated LCD Bias Voltage
2	VSS	-	Power Ground
3	VDD	-	Logic Power Supply
4	SDA	H/L	Serial Data Input/Output
5	POR	H/L	External Power On Reset
6	SCL	H/L	Serial Clock Input

## 7 LCD Initial Setting

LCD\_INIT:

```
LCALL IC_START
MOV A,#01110100B ;SLAVE ADDRESS
LCALL SEND_BYTE
MOV A,#00H ;SEND A CONTROL BYTE
LCALL SEND_BYTE
MOV A,#00110100b; ;FUNCTION SET 00100010
; 001 DL,0,M SL,H

LCALL SEND_BYTE
MOV A,#0CH ;DISPLAY ON
LCALL SEND_BYTE
LCALL DELAY1S
MOV A,#06H ;ENTRY MODE SET
LCALL SEND_BYTE
MOV A,#00110101b; ;FUNCTION SET 00100010
LCALL SEND_BYTE ; 001 DL,0,M SL,H
MOV A,#10011111b; ;VA=1 21h
LCALL SEND_BYTE ; VLCD = (integer value of register* 0.082) + 1.8=4.5v
;integer value of register=21h

LCALL DELAY1S
MOV A,#00110100b; ;FUNCTION SET 00100010
LCALL SEND_BYTE ; 001 DL,0,M SL,H
ACALL IC_STOP
RET
```



## 8 TIMING CHARACTERISTICS

### Write Operation

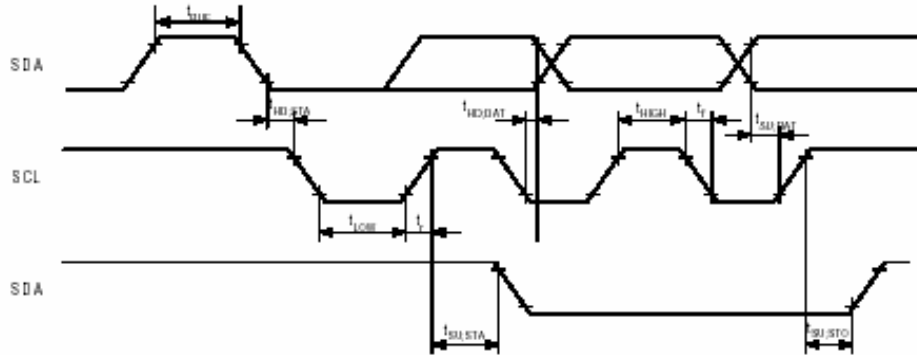

Timing characteristics: I <sup>2</sup> C-bus interface (input capacitance $C_i = 10\text{pF}$ )					
f <sub>SCL</sub>	SCL clock frequency	–	–	400	KHz
t <sub>LOW</sub>	SCL clock low period	1.3	–	–	μs
t <sub>HIGH</sub>	SCL clock high period	0.6	–	–	μs
t <sub>SU,DA</sub>	data set-up time	100	–	–	ns
t <sub>HD,DA</sub>	data hold time	0	–	–	ns
t <sub>r</sub>	SCL, SDA rise time	–	–	300	ns
t <sub>f</sub>	SCL, SDA fall time	–	–	300	ns
C <sub>B</sub>	capacitive bus line load	–	–	400	pF
t <sub>SU,STA</sub>	set-up time for a repeated START condition	0.6	–	–	μs
t <sub>HD,STA</sub>	START condition hold time	0.6	–	–	μs
t <sub>SU,STO</sub>	set-up time for STOP condition	0.6	–	–	μs
t <sub>SW</sub>	tolerable spike width on bus	–	–	50	ns

## 9 FONT TABLE

upper 4bits lower 4bits	0100	0001	0110	0111	0101	0101	0110	0111	1100	1101	1110	1111	1100	1101	1110	1111
max 0001	1	⦿	⦿	⦿	⦿	⦿	⦿	⦿	⦿	⦿	⦿	⦿	⦿	⦿	⦿	⦿
max 0001	2	⦿	⦿	⦿	⦿	⦿	⦿	⦿	⦿	⦿	⦿	⦿	⦿	⦿	⦿	⦿
max 0011	3	⦿	⦿	⦿	⦿	⦿	⦿	⦿	⦿	⦿	⦿	⦿	⦿	⦿	⦿	⦿
max 0111	4	⦿	⦿	⦿	⦿	⦿	⦿	⦿	⦿	⦿	⦿	⦿	⦿	⦿	⦿	⦿
max 0101	5	⦿	⦿	⦿	⦿	⦿	⦿	⦿	⦿	⦿	⦿	⦿	⦿	⦿	⦿	⦿
max 0101	6	⦿	⦿	⦿	⦿	⦿	⦿	⦿	⦿	⦿	⦿	⦿	⦿	⦿	⦿	⦿
max 0111	7	⦿	⦿	⦿	⦿	⦿	⦿	⦿	⦿	⦿	⦿	⦿	⦿	⦿	⦿	⦿
max 0111	8	⦿	⦿	⦿	⦿	⦿	⦿	⦿	⦿	⦿	⦿	⦿	⦿	⦿	⦿	⦿
max 1001	9	⦿	⦿	⦿	⦿	⦿	⦿	⦿	⦿	⦿	⦿	⦿	⦿	⦿	⦿	⦿
max 1001	10	⦿	⦿	⦿	⦿	⦿	⦿	⦿	⦿	⦿	⦿	⦿	⦿	⦿	⦿	⦿
max 1011	11	⦿	⦿	⦿	⦿	⦿	⦿	⦿	⦿	⦿	⦿	⦿	⦿	⦿	⦿	⦿
max 1011	12	⦿	⦿	⦿	⦿	⦿	⦿	⦿	⦿	⦿	⦿	⦿	⦿	⦿	⦿	⦿
max 1100	13	⦿	⦿	⦿	⦿	⦿	⦿	⦿	⦿	⦿	⦿	⦿	⦿	⦿	⦿	⦿
max 1111	14	⦿	⦿	⦿	⦿	⦿	⦿	⦿	⦿	⦿	⦿	⦿	⦿	⦿	⦿	⦿
max 1111	15	⦿	⦿	⦿	⦿	⦿	⦿	⦿	⦿	⦿	⦿	⦿	⦿	⦿	⦿	⦿
max 1111	16	⦿	⦿	⦿	⦿	⦿	⦿	⦿	⦿	⦿	⦿	⦿	⦿	⦿	⦿	⦿

## 10 QUALITY AND RELIABILITY

### 10.1 TEST CONDITIONS

Tests should be conducted under the following conditions :

Ambient temperature :  $20 \pm 5^{\circ}\text{C}$

Humidity :  $60 \pm 25\% \text{ RH}$ .

### 10.2 SAMPLING PLAN

Sampling method shall be in accordance with MIL-STD-105E , level II, normal single sampling plan .

### 10.3 ACCEPTABLE QUALITY LEVEL

A major defect is defined as one that could cause failure to or materially reduce the usability of the unit for its intended purpose. A minor defect is one that does not materially reduce the usability of the unit for its intended purpose or is an infringement from established standards and has no significant bearing on its effective use or operation.

### 10.4 APPEARANCE

An appearance test should be conducted by human sight at approximately 30 cm distance from the LCD module under fluorescent light. The inspection area of LCD panel shall be within the range of following limits.

## 10.5 INSPECTION QUALITY CRITERIA

Item	Description of defects			Class of Defects	Acceptable level (%)
Function	Short circuit or Pattern cut			Major	0.65
Dimension	Deviation from drawings			Major	1.5
Black spots	Ave . dia . D	area A	area B	Minor	2.5
	$D \leq 0.2$	Disregard			
	$0.2 < D \leq 0.3$	3	4		
	$0.3 < D \leq 0.4$	2	3		
	$0.4 < D$	0	1		
Black lines	Width W, Length L	A	B	Minor	2.5
	$W \leq 0.03$	disregard			
	$0.03 < W \leq 0.05$	3	4		
	$0.05 < W \leq 0.07, L \leq 3.0$	1	1		
	See line criteria				
Bubbles in polarizer	Average diameter D $0.2 < D < 0.5$ mm for N = 4 , D > 0.5 for N = 1			Minor	2.5
Color uniformity	Rainbow color or newton ring.			Minor	2.5
Glass Scratches	Obvious visible damage.			Minor	2.5
Contrast ratio	See note 1			Minor	2.5
Response time	See note 2			Minor	2.5
Viewing angle	See note 3			Minor	2.5

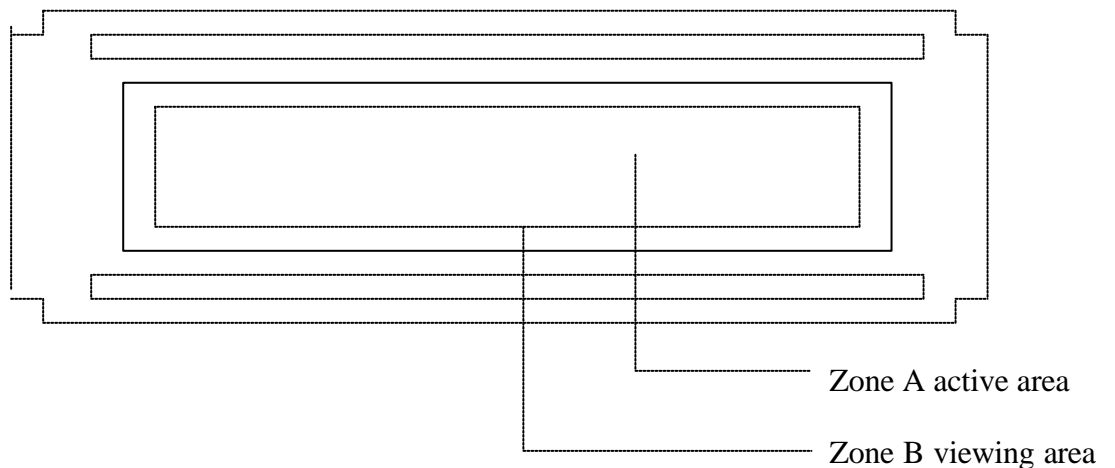

## 10.6 RELIABILITY

Test Item	Test Conditions	Note
	Normal Temp. type	
High Temperature Operation	50±3°C , t=96 hrs	
Low Temperature Operation	-10±3°C , t=96 hrs	
High Temperature Storage	60±3°C , t=96 hrs	1,2
Low Temperature Storage	-20±3°C , t=96 hrs	1,2
Temperature Cycle	-20°C ~ 25°C ~ 60°C 30 min. 5 min. 30 min. ( 1 cycle ) Total 5 cycle	1,2
Humidity Test	40 °C, Humidity 90%, 96 hrs	1,2
Vibration Test (Packing)	Sweep frequency : 10 ~ 55 ~ 10 Hz/1min Amplitude : 0.75mm Test direction : X.Y.Z/3 axis Duration : 30min/each axis	2

Note 1 : Condensation of water is not permitted on the module.

Note 2 : The module should be inspected after 1 hour storage in normal conditions  
(15-35°C , 45-65%RH).

Definitions of life end point :

- Current drain should be smaller than the specific value.
- Function of the module should be maintained.
- Appearance and display quality should not have degraded noticeably.
- Contrast ratio should be greater than 50% of the initial value.

## **11 HANDLING PRECAUTIONS**

- (1) A LCD module is a fragile item and should not be subjected to strong mechanical shocks.
- (2) Avoid applying pressure to the module surface. This will distort the glass and cause a change in color.
- (3) Under no circumstances should the position of the bezel tabs or their shape be modified.
- (4) Do not modify the display PCB in either shape or positioning of components.
- (5) Do not modify or move location of the zebra or heat seal connectors.
- (6) The device should only be soldered to during interfacing. Modification to other areas of the board should not be carried out.
- (7) In the event of LCD breakage and resultant leakage of fluid do not inhale, ingest or make contact with the skin. If contact is made rinse immediately.
- (8) When cleaning the module use a soft damp cloth with a mild solvent, such as Isopropyl or Ethyl alcohol. The use of water, ketone or aromatic is not permitted.
- (9) Prior to initial power up input signals should not be applied.
- (10) Protect the module against static electricity and observe appropriate anti-static precautions.

# 12 OUTLINE DIMENSION

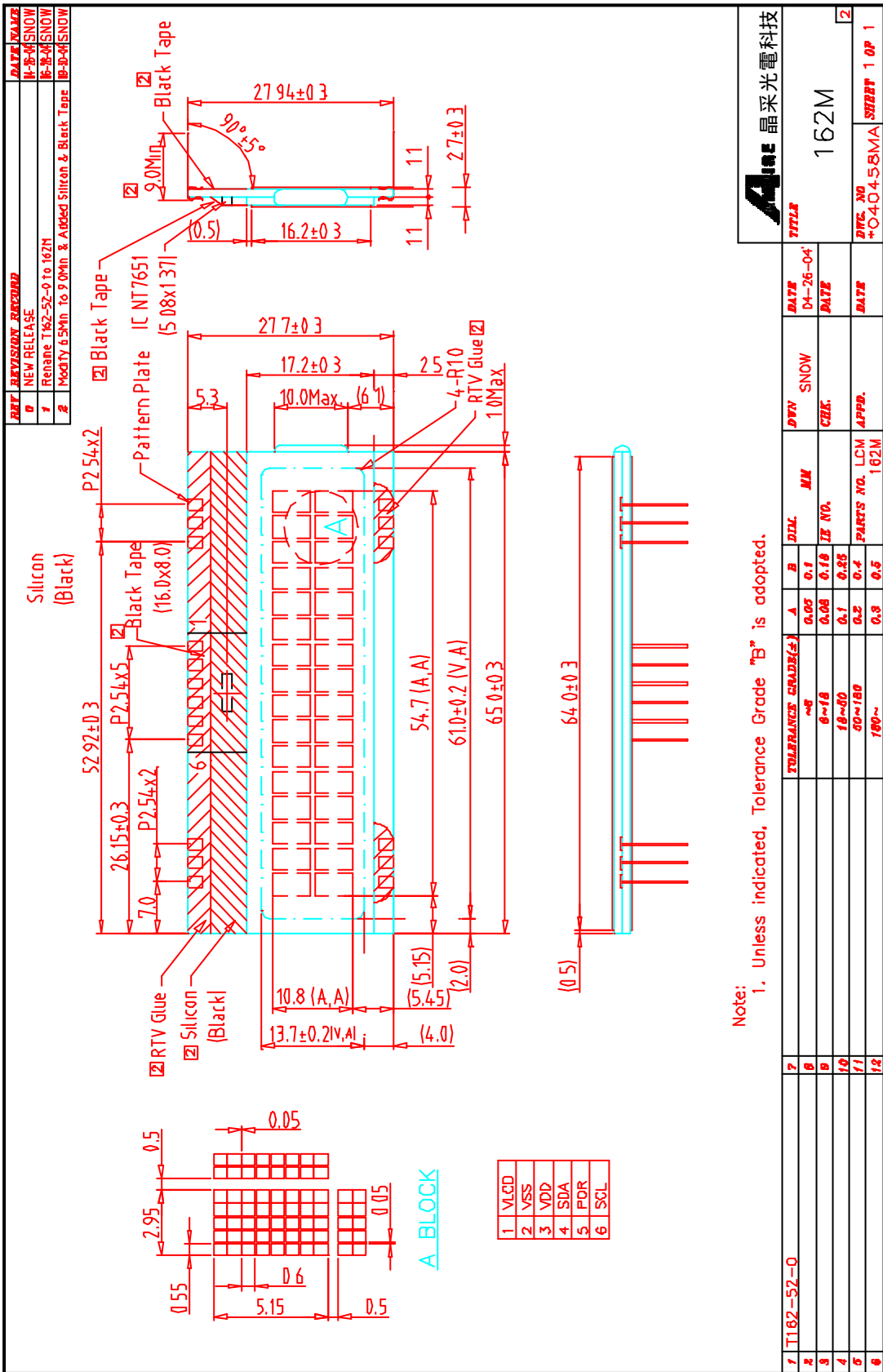

Note: 1. Unless indicated, Tolerance Grade "B" is adopted.

**Amie** 晶采光电科技

**TITLE** 162M

**DATE** D4-26-04

**DRY** SNOW

**CHK.**

**APPR.**

**PWC. NO** +O4O458MA

**SHEET** 1 OP 1