

MEMS Capacitive Accelerometers

Application Notes

MS8000 Evaluation Board - EVBA

30EVB.MS8X.J.03.08

Features

Mounted accelerometer
Fully assembled
MS8000 and HS8000 compatible
Analog voltage output (0.5V to 4.5V)

Applications

Inertial sensing
Tilt sensing
Vibration sensing

Introduction

The Evaluation Board EVBA version offers to the user a simple and quick means to evaluate the main functionality and a full performance of the Colibrys MS8000 and HS8000 accelerometer series.

The MS8000 product is a MEMS capacitive accelerometer based on a bulk micro-machined silicon element, a low power ASIC for signal conditioning, a micro-controller for storage of compensation values and a temperature sensor (Fig. 1).

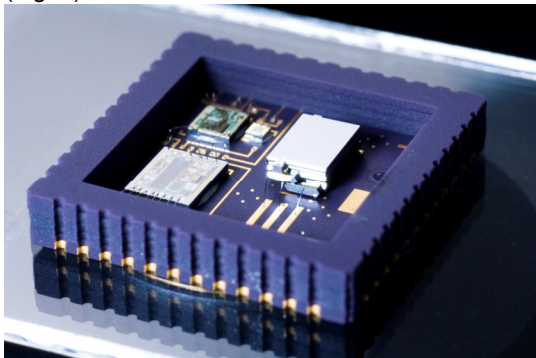

Fig. 1 : Open view of a MS8000 product

The MS8000 is operating from a single power supply voltage (between 2.5V and 5.5V) with a low current consumption (< 0.5mA at 5V). The output is a ratiometric analog voltage that varies between 0.5V and 4.5V for the full-scale acceleration range at a voltage supply of 5V. The sensor is fully self-contained and packaged in a 48-pin LCC ceramic housing, thus insuring a full hermeticity. It operates over a temperature range of -55°C to 125°C and can withstand shocks up to 6000g without performance degradation. For further technical information please refer to the related specification and product description.

EVBA general description

This small Evaluation Board circuit is intended to help the system designer or qualification engineer to speed-up the evaluation and integration of the MS/HS8000 accelerometer series to any new or upgraded systems. It is simple to use and as no additional components are required, it can easily be connected to a power supply and a voltmeter to read the accelerometer output and temperature signal through the 6-pin connector.

Board layout and components

The EVBA (Fig. 2) is very simple and mainly comprises three decoupling capacitors. The precise evaluation board components and related functionality are summarized in the following table.

A schematic of the EVBA is presented in Fig. 3 as the layout and the outline dimensions are presented in Fig. 4 and Fig. 5, both represented in the next page.



Fig. 2 : View of the EVBA

| Component | Value | Function |
|-----------|---------------|---------------------------------------|
| C1 | 1 μ F | Decoupling capacitor VDD - VSS |
| C2 | 1 μ F | Decoupling capacitor VAGND - VDD |
| C3 | 1 μ F | Decoupling capacitor VAGND - VSS |
| J1 | Connector | See Fig. 6 for details |
| J2 | End connector | See Fig. 6 for details |
| U1 | Accelerometer | 1 axis accelerometer |
| Screw | Diam 3.2mm | To fix the evaluation board |
| Spacer | Diam 6mm | To isolate the back side of the board |

Mounting recommendations

The EVBA is designed to be mounted easily in various evaluation environments; the shaker (for dynamic measurements), the tumble table (for static and dynamic measurement) and the oven (for temperature measurement).

The sensitive axis (Z-axis) is perpendicular to the plan of EVBA. The mounting of the EVBA is critical to insure the

best measurements. Therefore it is important to mount the EVBA as tightly as possible to obtain accurate performance.

The connection cable, screw and spacer are also provided to guarantee a correct connection, fixation and isolation in different evaluation environments.

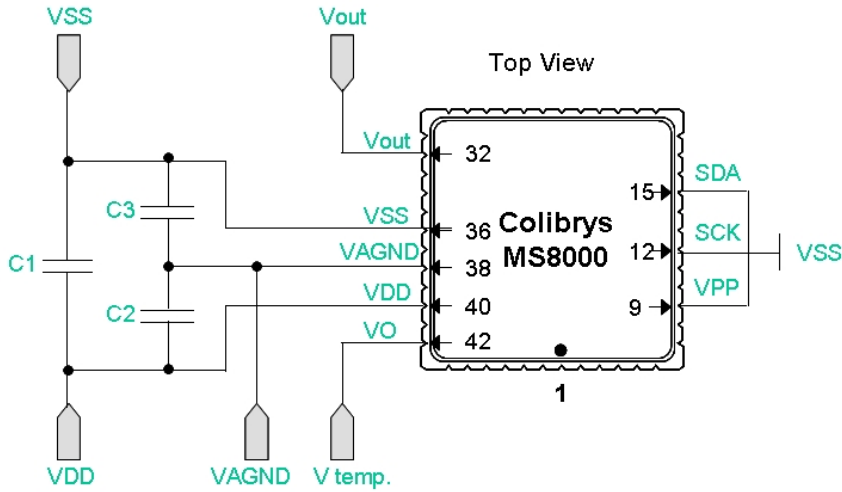

Fig. 3 : Schematic view of the Evaluation Board

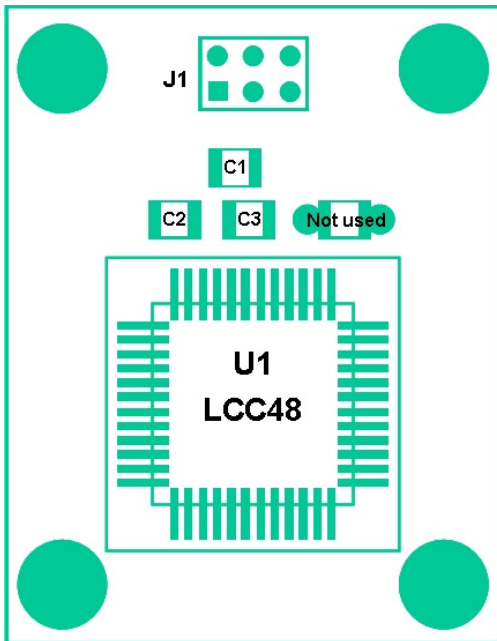

Fig. 4 : Layout of the EVBA

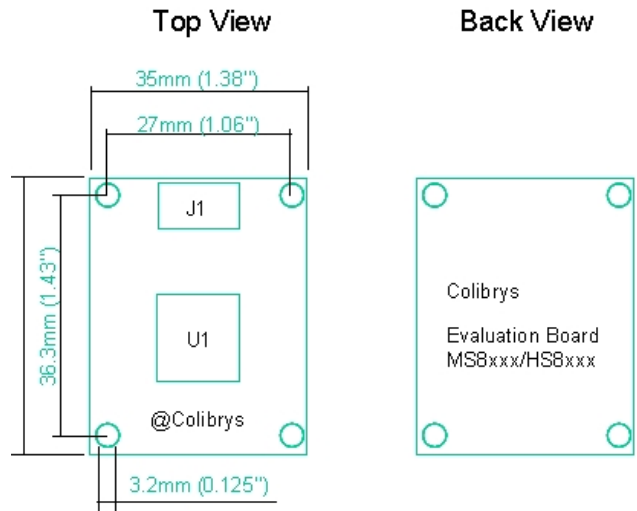

Fig. 5 : Evaluation Board outline dimensions

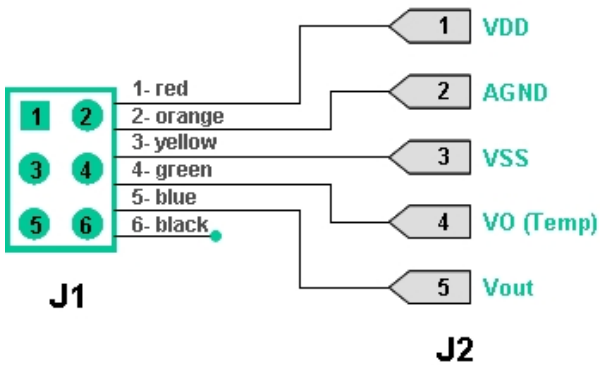

Fig. 6 : J1 and J2 connectors