

MIXED SIGNAL MICROCONTROLLER

FEATURES

- **Embedded Non-Volatile FRAM**
 - Supports Universal Memory
 - Ultra-Fast Ultra-Low-Power Write Cycle
 - Error Correction Coding (ECC)
 - Memory Protection Unit
- **Low Supply Voltage Range, 2.0 V to 3.6 V**
- **16-Bit RISC Architecture, Up to 24-MHz**
- **Low Power Consumption**
 - **Active Mode (AM):**
All System Clocks Active
107 $\mu\text{A}/\text{MHz}$ at 8 MHz, 3.0 V, FRAM Program Execution (Typical)
60 $\mu\text{A}/\text{MHz}$ at 8 MHz, 3.0 V, RAM Program Execution (Typical)
 - **Standby Mode (LPM3):**
Real-Time Clock With Crystal, Watchdog, and Supply Supervisor Operational, Full System State Retention:
8 μA at 3.0 V (Typical)
Low-Power Oscillator (VLO), General-Purpose Counter, Watchdog, and Supply Supervisor Operational, Full System State Retention:
7.5 μA at 3.0 V (Typical)
 - **Off Mode (LPM4):**
Full System State Retention, Supply Supervisor Operational:
7.5 μA at 3.0 V (Typical)
 - **Real-Time Clock Mode (LPM3.5):**
3.0 μA at 3.0 V (Typical)
 - **Shutdown Mode (LPM4.5):**
0.32 μA at 3.0 V (Typical)
- **Power Management System**
 - Fully Integrated LDO
 - Supply Voltage Supervision and Brownout
- **Clock System**
 - Factory Trimmed DCO With Three Selectable Frequencies
 - Low-Power/Low-Frequency Internal Clock Source (VLO)
 - 32-kHz Watch Crystals and High-Frequency Crystals up to 24 MHz
- **16-Bit Timer TA0, Timer_A With Three Capture/Compare Registers**
- **16-Bit Timer TA1, Timer_A With Three Capture/Compare Registers**
- **16-Bit Timer TB0, Timer_B With Three Capture/Compare Shadow Registers**
- **16-Bit Timer TB1, Timer_B With Three Capture/Compare Shadow Registers**
- **16-Bit Timer TB2, Timer_B With Three Capture/Compare Shadow Registers**
- **Enhanced Universal Serial Communication Interfaces**
 - eUSCI_A0 and eUSCI_A1 Each Supporting
 - Enhanced UART supporting Auto-Baudrate Detection
 - IrDA Encoder and Decoder
 - Synchronous SPI
 - eUSCI_B0 Supporting
 - I²C With Multi-Slave Addressing
 - Synchronous SPI
- **10-Bit Analog-to-Digital (A/D) Converter With Internal Reference, Sample-and-Hold**
- **On-chip Comparator**
- **Hardware Multiplier Supporting 32-Bit Operations**
- **Three Channel Internal DMA**
- **Real-Time Clock with Calendar and Alarm Functions**
- **Serial Onboard Programming, No External Programming Voltage Needed**
- **Family Members and Available Options Are Summarized in [Table 1](#).**
- **For Complete Module Descriptions, See the *MSP430FR57xx Family User's Guide* ([SLAU272](#))**



Please be aware that an important notice concerning availability, standard warranty, and use in critical applications of Texas Instruments semiconductor products and disclaimers thereto appears at the end of this data sheet.

CAUTION These products use FRAM non-volatile memory technology. FRAM retention is sensitive to extreme temperatures, such as those experienced during reflow or hand soldering. See [Absolute Maximum Ratings](#) for more information.

DESCRIPTION

The Texas Instruments MSP430™ family of low-power microcontrollers consists of several devices featuring different sets of peripherals targeted for various applications. The architecture, combined with seven low-power modes is optimized to achieve extended battery life in portable measurement applications. The device features a powerful 16-bit RISC CPU, 16-bit registers, and constant generators that contribute to maximum code efficiency.

The MSP430FR572x and MSP430FR573x devices are microcontroller configurations with up to five 16-bit timers, comparator, universal serial communication interfaces (eUSCI) supporting UART, SPI, and I2C, hardware multiplier, DMA, real-time clock module with alarm capabilities, up to 33 I/O pins, and an optional high-performance 10-bit analog-to-digital converter (ADC). Family members available are summarized in [Table 1](#).

Table 1. Family Members

Device	FRAM (KB)	SRAM (KB)	System Clock (MHz)	ADC10_B	Comp_D	Timer_A ⁽¹⁾	Timer_B ⁽²⁾	eUSCI		I/O	Package Types
								Channel A: UART/IrDA/SPI	Channel B: SPI/I ² C		
MSP430FR5739	16	1	24	12 ext / 2 int ch.	16 ch.	3, 3	3, 3, 3	2	1	32	RHA
										30	DA
MSP430FR5738	16	1	24	6 ext / 2 int ch.	10 ch.	3, 3	3	1	1	17	RGE
				8 ext / 2 int ch.	12 ch.					21	PW ⁽³⁾
MSP430FR5737 ⁽³⁾	16	1	24		16 ch.	3, 3	3, 3, 3	2	1	32	RHA ⁽³⁾
										30	DA ⁽³⁾
MSP430FR5736 ⁽³⁾	16	1	24		10 ch.	3, 3	3	1	1	17	RGE ⁽³⁾
					12 ch.					21	PW ⁽³⁾
MSP430FR5735	8	1	24	12 ext / 2 int ch.	16 ch.	3, 3	3, 3, 3	2	1	32	RHA
										30	DA ⁽³⁾
MSP430FR5734 ⁽³⁾	8	1	24	6 ext / 2 int ch.	10 ch.	3, 3	3	1	1	17	RGE ⁽³⁾
				8 ext / 2 int ch.	12 ch.					21	PW ⁽³⁾
MSP430FR5733 ⁽³⁾	8	1	24		16 ch.	3, 3	3, 3, 3	2	1	32	RHA ⁽³⁾
										30	DA ⁽³⁾
MSP430FR5732 ⁽³⁾	8	1	24		10 ch.	3, 3	3	1	1	17	RGE ⁽³⁾
					12 ch.					21	PW ⁽³⁾
MSP430FR5731 ⁽³⁾	4	0.5	24	12 ext / 2 int ch.	16 ch.	3, 3	3, 3, 3	2	1	32	RHA ⁽³⁾
										30	DA ⁽³⁾
MSP430FR5730	4	0.5	24	6 ext / 2 int ch.	10 ch.	3, 3	3	1	1	17	RGE
				8 ext / 2 int ch.	12 ch.					21	PW ⁽³⁾
MSP430FR5729	16	1	8	12 ext / 2 int ch.	16 ch.	3, 3	3, 3, 3	2	1	32	RHA
										30	DA
MSP430FR5728	16	1	8	6 ext / 2 int ch.	10 ch.	3, 3	3	1	1	17	RGE
				8 ext / 2 int ch.	12 ch.					21	PW ⁽³⁾

- (1) Each number in the sequence represents an instantiation of Timer_A with its associated number of capture compare registers and PWM output generators available. For example, a number sequence of 3, 5 would represent two instantiations of Timer_A, the first instantiation having 3 and the second instantiation having 5 capture compare registers and PWM output generators, respectively.
- (2) Each number in the sequence represents an instantiation of Timer_B with its associated number of capture compare registers and PWM output generators available. For example, a number sequence of 3, 5 would represent two instantiations of Timer_B, the first instantiation having 3 and the second instantiation having 5 capture compare registers and PWM output generators, respectively.
- (3) Product Preview

Table 1. Family Members (continued)

Device	FRAM (KB)	SRAM (KB)	System Clock (MHz)	ADC10_B	Comp_D	Timer_A ⁽¹⁾	Timer_B ⁽²⁾	eUSCI		I/O	Package Types
								Channel A: UART/IrDA/SPI	Channel B: SPI/I ² C		
MSP430FR5727 ⁽³⁾	16	1	8		16 ch.	3, 3	3, 3, 3	2	1	32	RHA ⁽³⁾
										30	DA ⁽³⁾
MSP430FR5726 ⁽³⁾	16	1	8		10 ch.	3, 3	3	1	1	17	RGE ⁽³⁾
					12 ch.					21	PW ⁽³⁾
MSP430FR5725	8	1	8	12 ext / 2 int ch.	16 ch.	3, 3	3, 3, 3	2	1	32	RHA
										30	DA ⁽³⁾
MSP430FR5724 ⁽³⁾	8	1	8	6 ext / 2 int ch.	10 ch.	3, 3	3	1	1	17	RGE ⁽³⁾
				8 ext / 2 int ch.	12 ch.					21	PW ⁽³⁾
MSP430FR5723 ⁽³⁾	8	1	8		16 ch.	3, 3	3, 3, 3	2	1	32	RHA ⁽³⁾
										30	DA ⁽³⁾
MSP430FR5722 ⁽³⁾	8	1	8		10 ch.	3, 3	3	1	1	17	RGE ⁽³⁾
					12 ch.					21	PW ⁽³⁾
MSP430FR5721 ⁽³⁾	4	0.5	8	12 ext / 2 int ch.	16 ch.	3, 3	3, 3, 3	2	1	32	RHA ⁽³⁾
										30	DA ⁽³⁾
MSP430FR5720	4	0.5	8	6 ext / 2 int ch.	10 ch.	3, 3	3	1	1	17	RGE
				8 ext / 2 int ch.	12 ch.					21	PW ⁽³⁾

Table 2. Ordering Information⁽¹⁾

T _A	PACKAGED DEVICES ⁽²⁾			
	PLASTIC 40-PIN VQFN (RHA)	PLASTIC 24-PIN VQFN (RGE)	PLASTIC 38-PIN TSSOP (DA)	PLASTIC 28-PIN TSSOP (PW)
–40°C to 85°C	MSP430FR5721IRHA ⁽³⁾	MSP430FR5720IRGE	MSP430FR5721IDA ⁽³⁾	MSP430FR5720IPW ⁽³⁾
	MSP430FR5723IRHA ⁽³⁾	MSP430FR5722IRGE ⁽³⁾	MSP430FR5723IDA ⁽³⁾	MSP430FR5722IPW ⁽³⁾
	MSP430FR5725IRHA	MSP430FR5724IRGE ⁽³⁾	MSP430FR5725IDA ⁽³⁾	MSP430FR5724IPW ⁽³⁾
	MSP430FR5727IRHA ⁽³⁾	MSP430FR5726IRGE ⁽³⁾	MSP430FR5727IDA ⁽³⁾	MSP430FR5726IPW ⁽³⁾
	MSP430FR5729IRHA	MSP430FR5728IRGE	MSP430FR5729IDA	MSP430FR5728IPW ⁽³⁾
	MSP430FR5731IRHA ⁽³⁾	MSP430FR5730IRGE	MSP430FR5731IDA ⁽³⁾	MSP430FR5730IPW ⁽³⁾
	MSP430FR5733IRHA ⁽³⁾	MSP430FR5732IRGE ⁽³⁾	MSP430FR5733IDA ⁽³⁾	MSP430FR5732IPW ⁽³⁾
	MSP430FR5735IRHA	MSP430FR5734IRGE ⁽³⁾	MSP430FR5735IDA ⁽³⁾	MSP430FR5734IPW ⁽³⁾
	MSP430FR5737IRHA ⁽³⁾	MSP430FR5736IRGE ⁽³⁾	MSP430FR5737IDA ⁽³⁾	MSP430FR5736IPW ⁽³⁾
	MSP430FR5739IRHA	MSP430FR5738IRGE	MSP430FR5739IDA	MSP430FR5738IPW ⁽³⁾

- (1) For the most current package and ordering information, see the Package Option Addendum at the end of this document, or see the TI web site at www.ti.com.
- (2) Package drawings, standard packing quantities, thermal data, symbolization, and PCB design guidelines are available at www.ti.com/package.
- (3) Product Preview

**Functional Block Diagram –
MSP430FR5721IRHA, MSP430FR5725IRHA, MSP430FR5729IRHA
MSP430FR5731IRHA MSP430FR5735IRHA, MSP430FR5739IRHA**

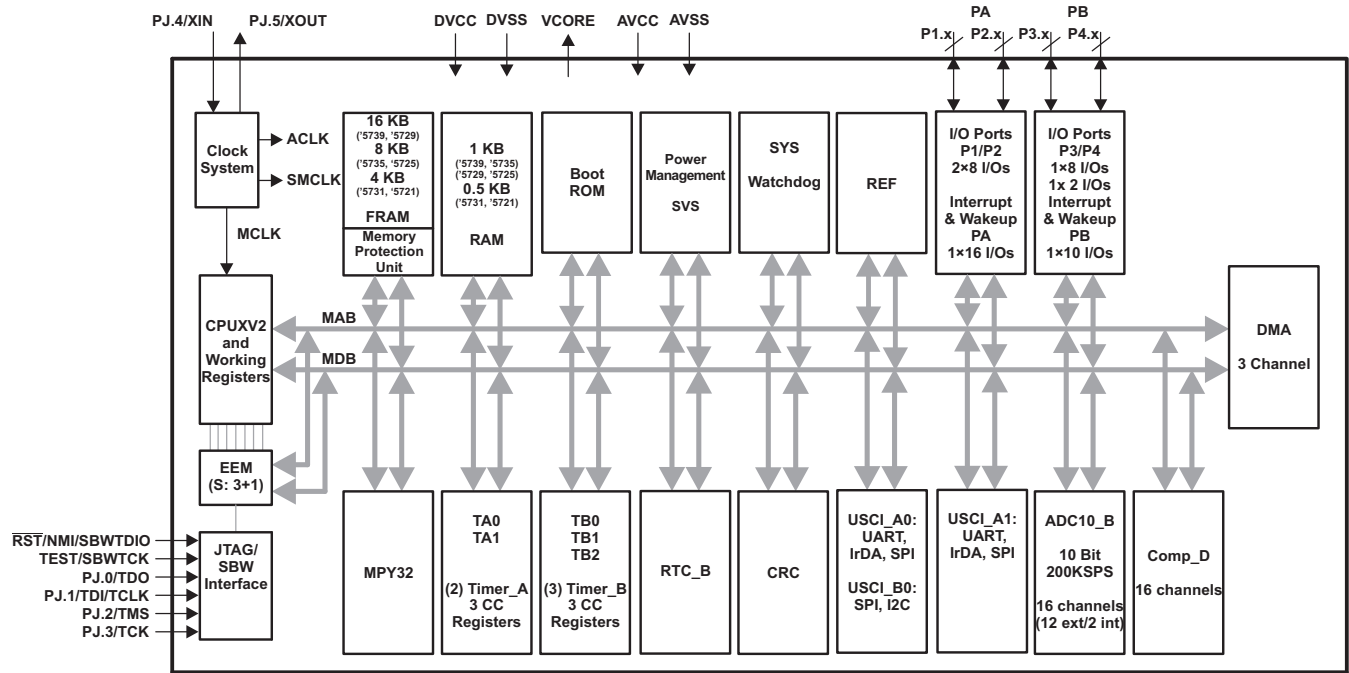

**Functional Block Diagram –
MSP430FR5723IRHA, MSP430FR5727IRHA
MSP430FR5733IRHA, MSP430FR5737IRHA**

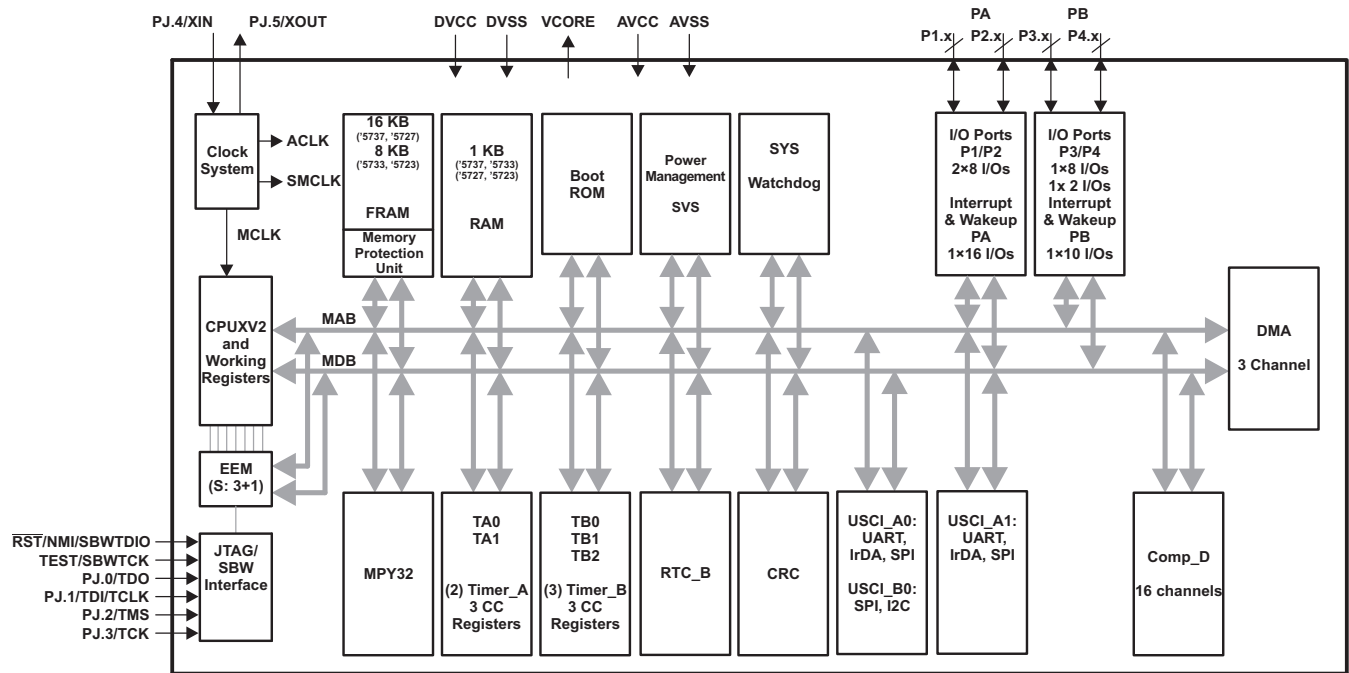

PRODUCT PREVIEW

**Pin Designation –
MSP430FR5721IRHA, MSP430FR5723IRHA, MSP430FR5725IRHA, MSP430FR5727IRHA,
MSP430FR5729IRHA
MSP430FR5731IRHA, MSP430FR5733IRHA, MSP430FR5735IRHA, MSP430FR5737IRHA,
MSP430FR5739IRHA**

**RHA PACKAGE
(TOP VIEW)**

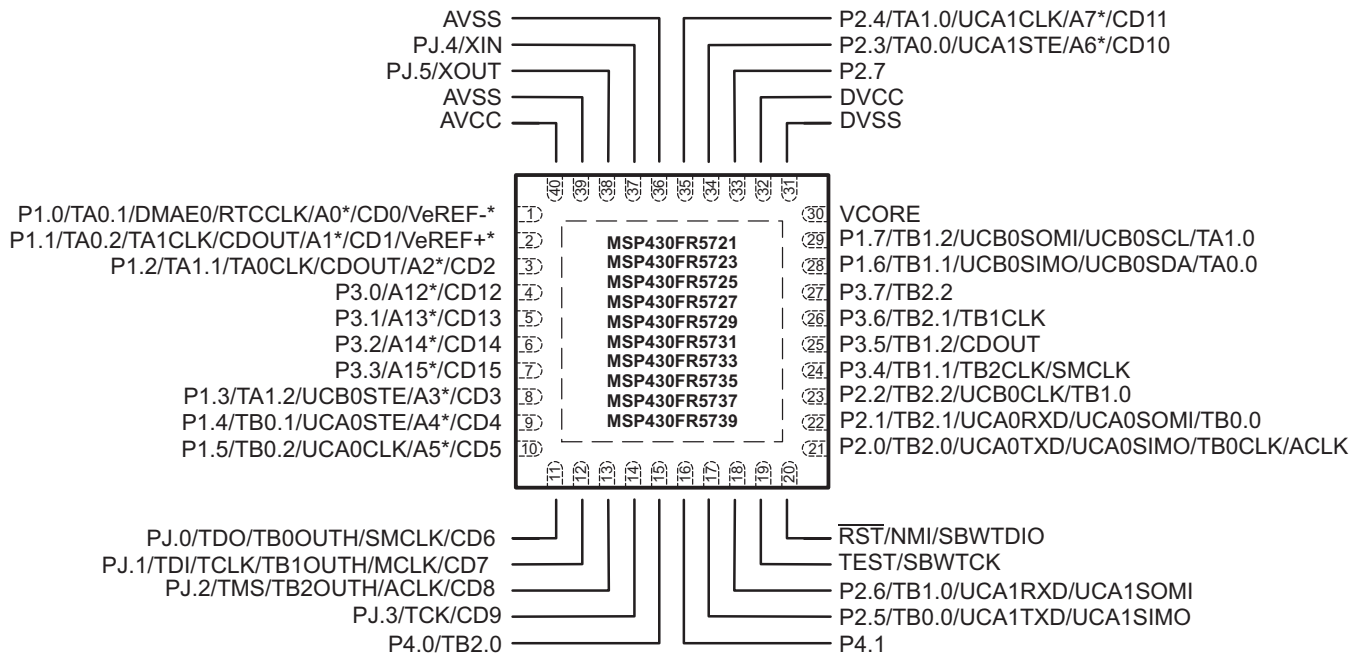

* Not available on MSP430FR5737, MSP430FR5733, MSP430FR5727, MSP430FR5723
Note: Power Pad connection to V_{SS} recommended.

PRODUCT PREVIEW

**Functional Block Diagram –
MSP430FR5721IDA, MSP430FR5725IDA, MSP430FR5729IDA
MSP430FR5731IDA MSP430FR5735IDA, MSP430FR5739IDA**

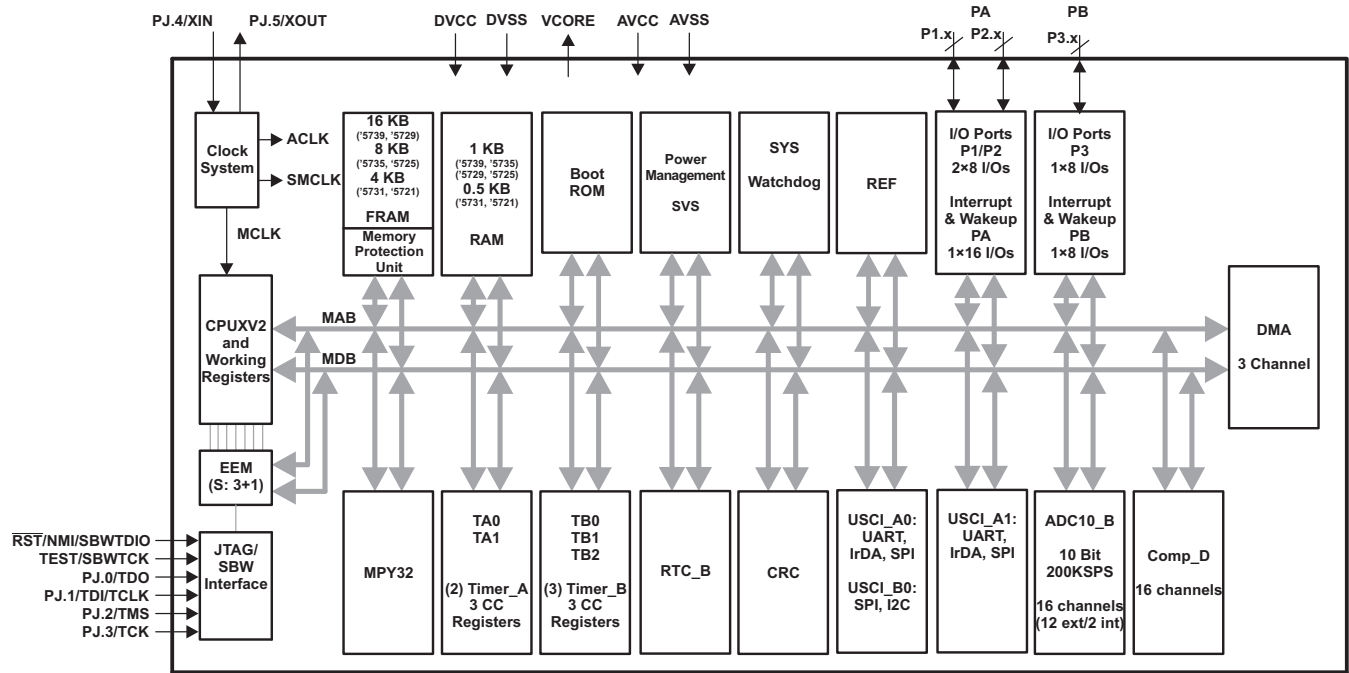

**Functional Block Diagram –
MSP430FR5723IDA, MSP430FR5727IDA
MSP430FR5733IDA, MSP430FR5737IDA**

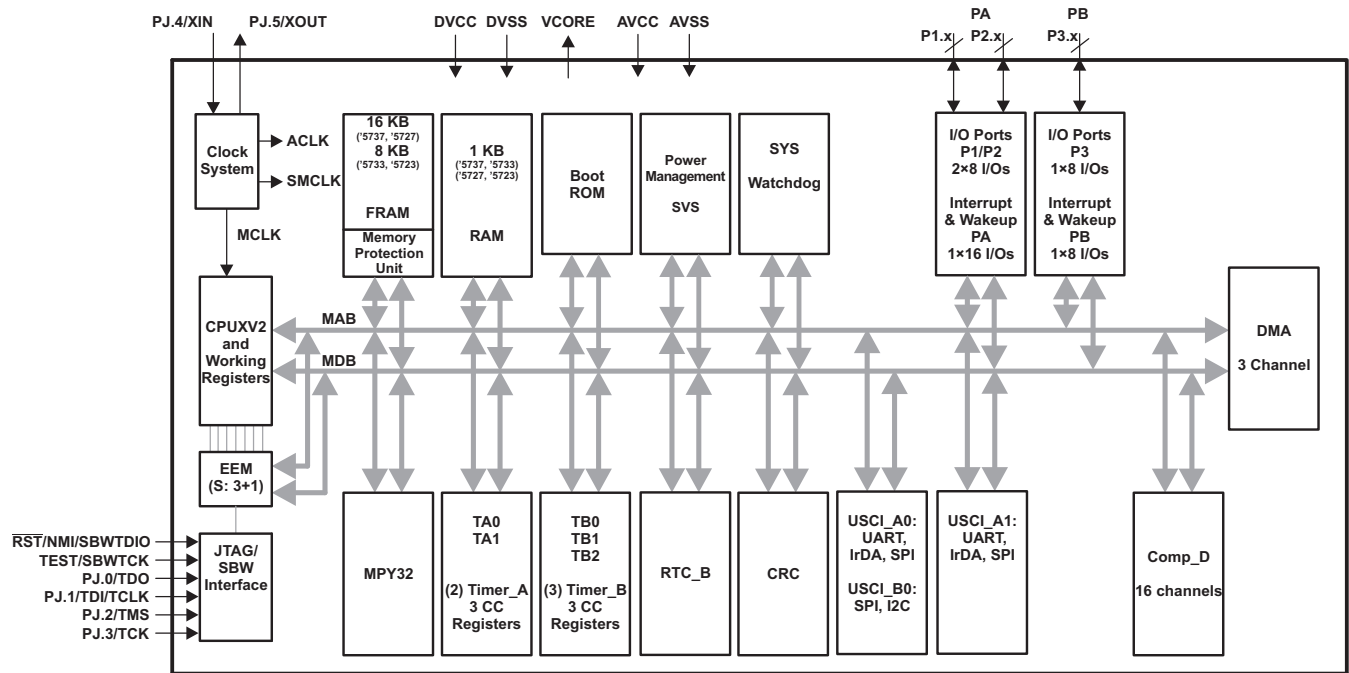

PRODUCT PREVIEW

**Pin Designation –
MSP430FR5721IDA, MSP430FR5723IDA, MSP430FR5725IDA, MSP430FR5727IDA,
MSP430FR5729IDA
MSP430FR5731IDA, MSP430FR5733IDA, MSP430FR5735IDA, MSP430FR5737IDA,
MSP430FR5739IDA**

**DA PACKAGE
(TOP VIEW)**

PJ.4/XIN	1	38	AVSS
PJ.5/XOUT	2	37	P2.4/TA1.0/UCA1CLK/A7*/CD11
AVSS	3	36	P2.3/TA0.0/UCA1STE/A6*/CD10
AVCC	4	35	P2.7
P1.0/TA0.1/DMAE0/RTCCLK/A0*/CD0/VeREF-*	5	34	DVCC
P1.1/TA0.2/TA1CLK/CDOOUT/A1*/CD1/VeREF+*	6	33	DVSS
P1.2/TA1.1/TA0CLK/CDOOUT/A2*/CD2	7	32	VCORE
P3.0/A12*/CD12	8	31	P1.7/TB1.2/UCB0SOMI/UCB0SCL/TA1.0
P3.1/A13*/CD13	9	30	P1.6/TB1.1/UCB0SIMO/UCB0SDA/TA0.0
P3.2/A14*/CD14	10	29	P3.7/TB2.2
P3.3/A15*/CD15	11	28	P3.6/TB2.1/TB1CLK
P1.3/TA1.2/UCB0STE/A3*/CD3	12	27	P3.5/TB1.2/CDOOUT
P1.4/TB0.1/UCA0STE/A4*/CD4	13	26	P3.4/TB1.1/TB2CLK/SMCLK
P1.5/TB0.2/UCA0CLK/A5*/CD5	14	25	P2.2/TB2.2/UCB0CLK/TB1.0
PJ.0/TDO/TB0OUTH/SMCLK/CD6	15	24	P2.1/TB2.1/UCA0RXD/UCA0SOMI/TB0.0
PJ.1/TDI/TCLK/TB1OUTH/MCLK/CD7	16	23	P2.0/TB2.0/UCA0TXD/UCA0SIMO/TB0CLK/ACLK
PJ.2/TMS/TB2OUTH/ACLK/CD8	17	22	RST/NMI/SBWTIO
PJ.3/TCK/CD9	18	21	TEST/SBWTCK
P2.5/TB0.0/UCA1TXD/UCA1SIMO	19	20	P2.6/TB1.0/UCA1RXD/UCA1SOMI

* Not available on MSP430FR5737, MSP430FR5733, MSP430FR5727, MSP430FR5723

PRODUCT PREVIEW

**Functional Block Diagram –
MSP430FR5720IRGE, MSP430FR5724IRGE, MSP430FR5728IRGE
MSP430FR5730IRGE MSP430FR5734IRGE, MSP430FR5738IRGE**

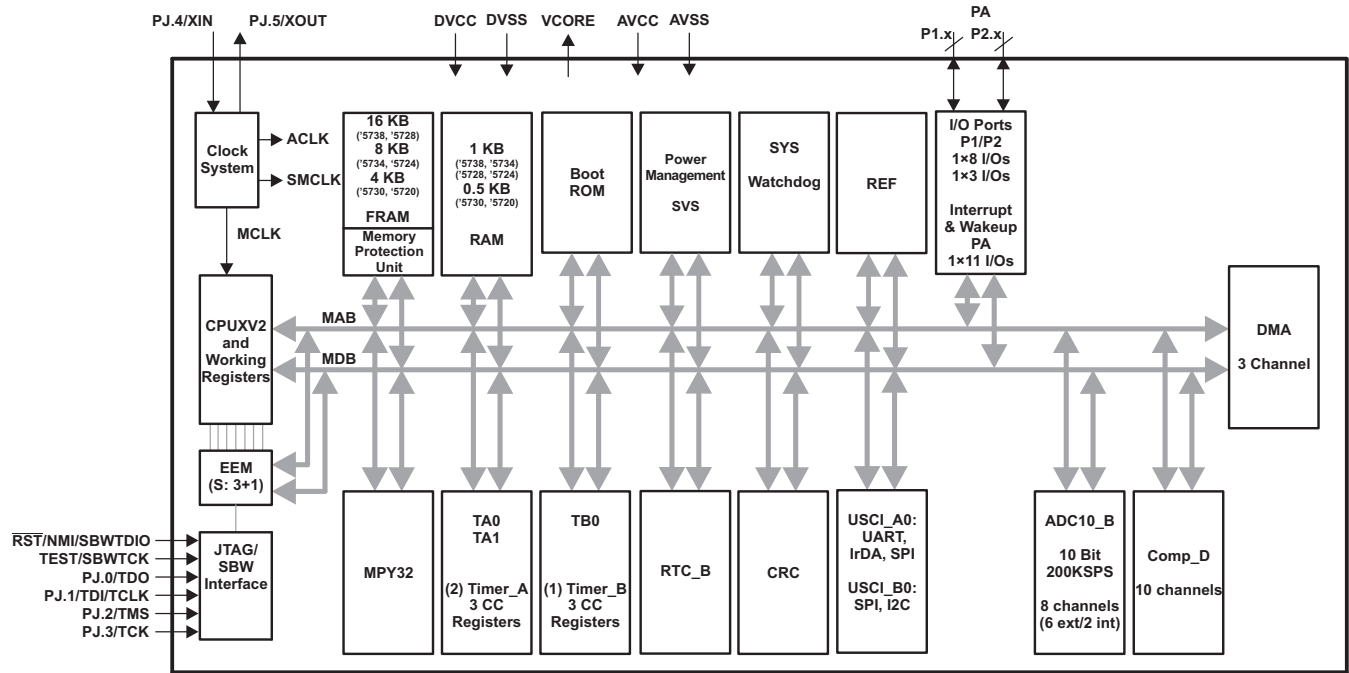

**Functional Block Diagram –
MSP430FR5722IRGE, MSP430FR5726IRGE
MSP430FR5732IRGE, MSP430FR5736IRGE**

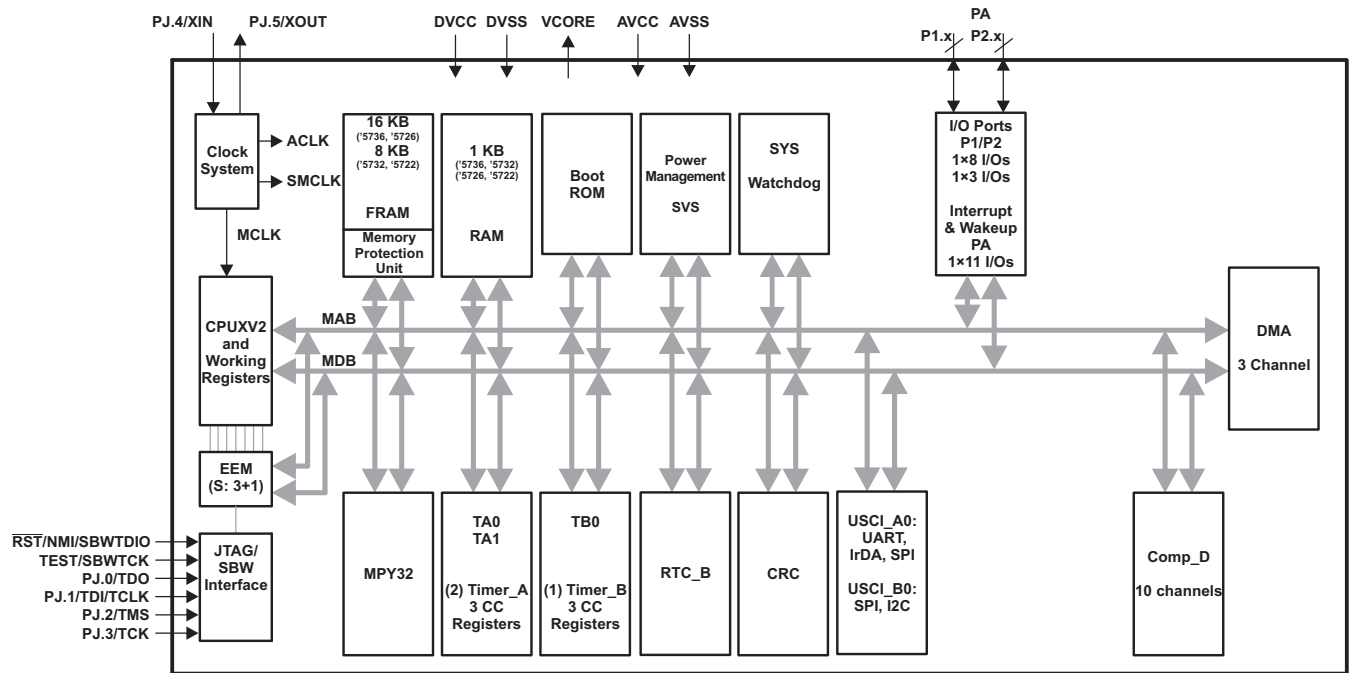

PRODUCT PREVIEW

**Pin Designation –
MSP430FR5720IRGE, MSP430FR5722IRGE, MSP430FR5724IRGE, MSP430FR5726IRGE,
MSP430FR5728IRGE
MSP430FR5730IRGE, MSP430FR5732IRGE, MSP430FR5734IRGE, MSP430FR5736IRGE,
MSP430FR5738IRGE**

**RGE PACKAGE
(TOP VIEW)**

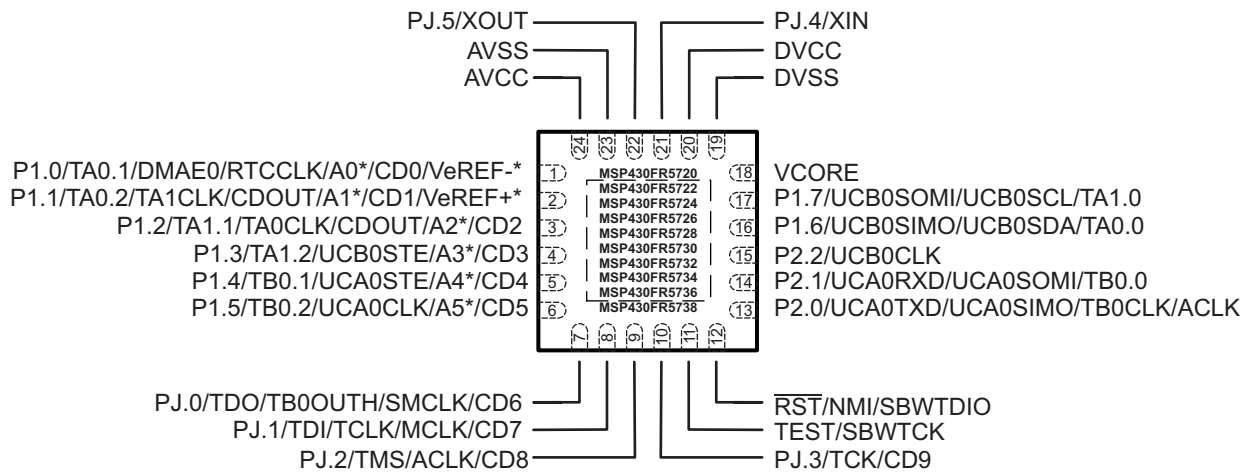

* Not available on MSP430FR5736, MSP430FR5732, MSP430FR5726, MSP430FR5722
Note: Power Pad connection to V_{SS} recommended.

PRODUCT PREVIEW

**Functional Block Diagram –
MSP430FR5720IPW, MSP430FR5724IPW, MSP430FR5728IPW
MSP430FR5730IPW MSP430FR5734IPW, MSP430FR5738IPW**

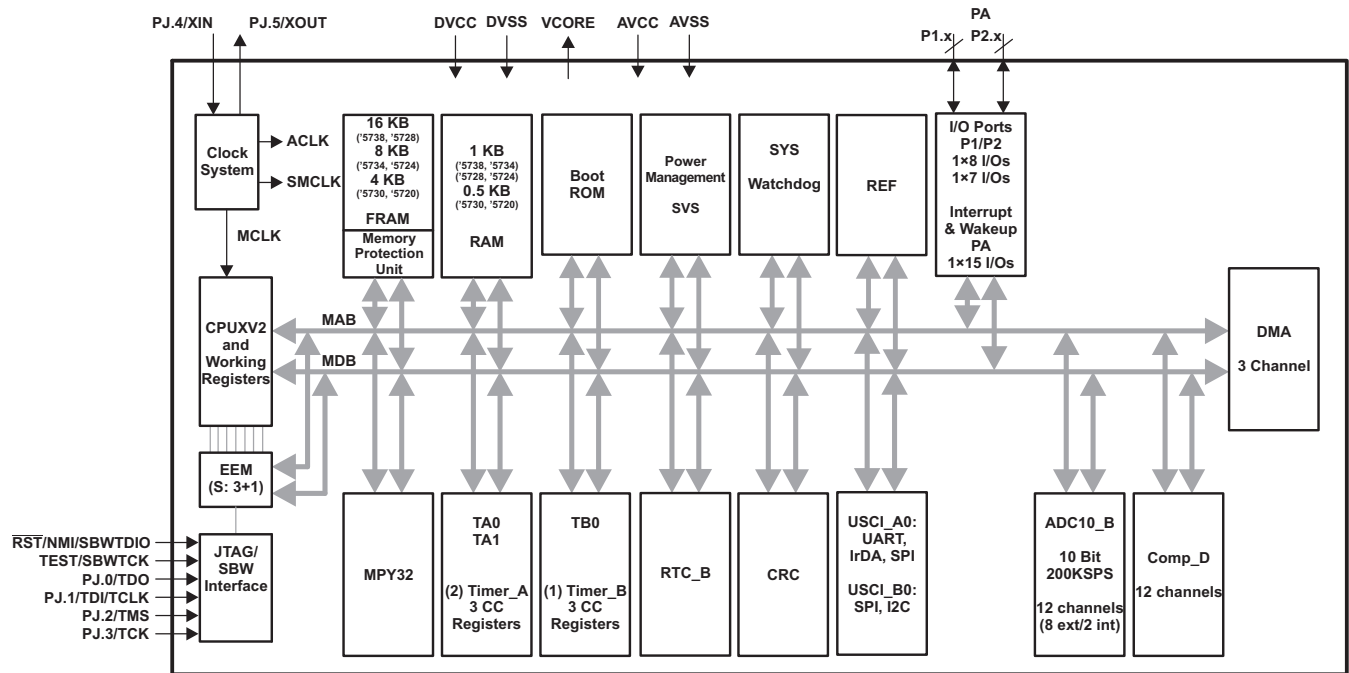

**Functional Block Diagram –
MSP430FR5722IPW, MSP430FR5726IPW
MSP430FR5732IPW, MSP430FR5736IPW**

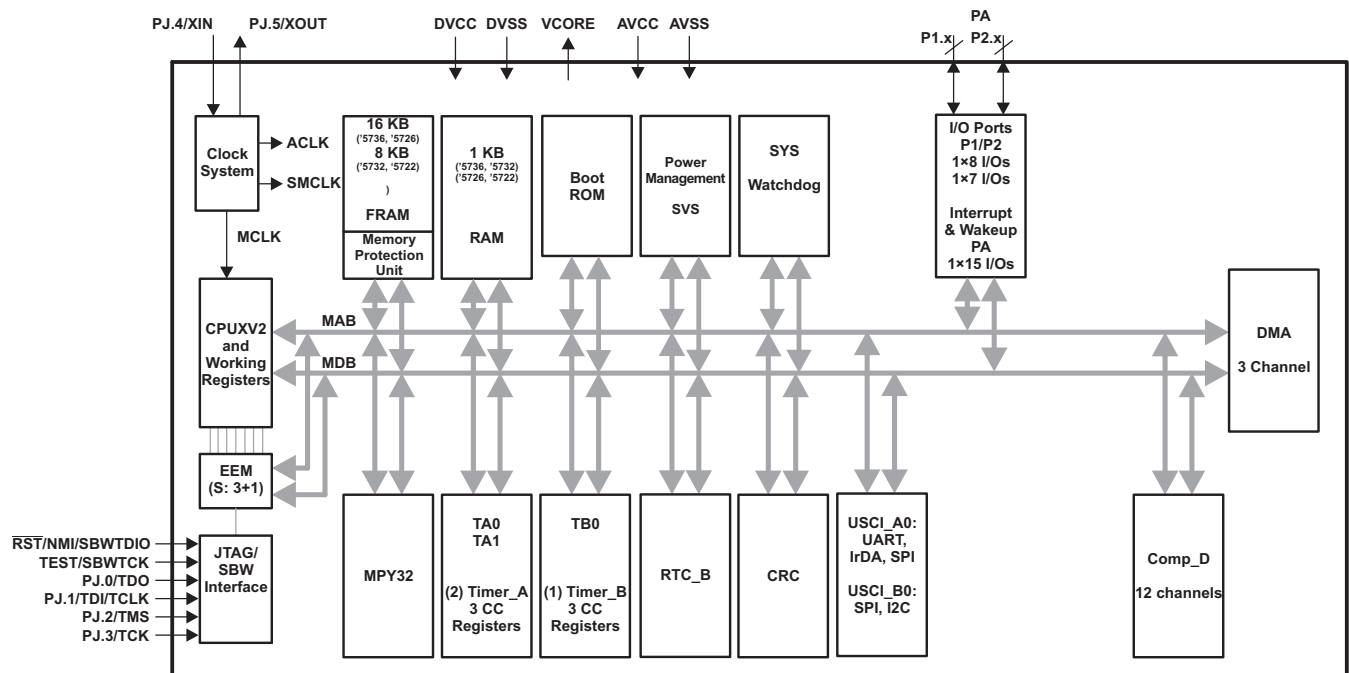

PRODUCT PREVIEW

**Pin Designation –
MSP430FR5720IPW, MSP430FR5722IPW, MSP430FR5724IPW, MSP430FR5726IPW,
MSP430FR5728IPW
MSP430FR5730IPW, MSP430FR5732IPW, MSP430FR5734IPW, MSP430FR5736IPW,
MSP430FR5738IPW**

**PW PACKAGE
(TOP VIEW)**

PJ.4/XIN	1	○	28	P2.4/TA1.0/A7*/CD11
PJ.5/XOUT	2		27	P2.3/TA0.0/A6*/CD10
AVSS	3		26	DVCC
AVCC	4	MSP430FR5738	25	DVSS
P1.0/TA0.1/DMAE0/RTCCLK/A0*/CD0/VeREF-*	5	MSP430FR5736	24	VCORE
P1.1/TA0.2/TA1CLK/CDOOUT/A1*/CD1/VeREF+*	6	MSP430FR5734	23	P1.7/UCB0SOMI/UCB0SCL/TA1.0
P1.2/TA1.1/TA0CLK/CDOOUT/A2*/CD2	7	MSP430FR5732	22	P1.6/UCB0SIMO/UCB0SDA/TA0.0
P1.3/TA1.2/UCB0STE/A3*/CD3	8	MSP430FR5730	21	P2.2/UCB0CLK
P1.4/TB0.1/UCA0STE/A4*/CD4	9	MSP430FR5728	20	P2.1/UCA0RXD/UCA0SOMI/TB0.0
P1.5/TB0.2/UCA0CLK/A5*/CD5	10	MSP430FR5726	19	P2.0/UCA0TXD/UCA0SIMO/TB0CLK/ACLK
PJ.0/TDO/TB0OUTH/SMCLK/CD6	11	MSP430FR5724	18	RST/NMI/SBWTDIO
PJ.1/TDI/TCLK/MCLK/CD7	12	MSP430FR5722	17	TEST/SBWTCK
PJ.2/TMS/ACLK/CD8	13		16	P2.6
PJ.3/TCK/CD9	14		15	P2.5/TB0.0

* Not available on MSP430FR5736, MSP430FR5732, MSP430FR5726, MSP430FR5722

PRODUCT PREVIEW

Table 3. TERMINAL FUNCTIONS

TERMINAL					I/O ⁽¹⁾	DESCRIPTION
NAME	NO.					
	RH A	RG E	DA	PW		
P1.0/TA0.1/DMAE0/ RTCCLK/A0/CD0/VeREF-	1	1	5	5	I/O	General-purpose digital I/O with port interrupt and wake up from LPMx.5 TA0 CCR1 capture: CCI1A input, compare: Out1 External DMA trigger RTC clock calibration output Analog input A0 – ADC (not available on devices without ADC) Comparator_D input CD0 External applied reference voltage (not available on devices without ADC)
P1.1/TA0.2/TA1CLK/ CDOOUT/A1/CD1/VeREF+	2	2	6	6	I/O	General-purpose digital I/O with port interrupt and wake up from LPMx.5 TA0 CCR2 capture: CCI2A input, compare: Out2 TA1 input clock Comparator_D output Analog input A1 – ADC (not available on devices without ADC) Comparator_D input CD1 Input for an external reference voltage to the ADC (not available on devices without ADC)
P1.2/TA1.1/TA0CLK/ CDOOUT/A2/CD2	3	3	7	7	I/O	General-purpose digital I/O with port interrupt and wake up from LPMx.5 TA1 CCR1 capture: CCI1A input, compare: Out1 TA0 input clock Comparator_D output Analog input A2 – ADC (not available on devices without ADC) Comparator_D input CD2
P3.0/A12/CD12	4	N/A	8	N/A	I/O	General-purpose digital I/O with port interrupt and wake up from LPMx.5 (not available on package options PW, RGE) Analog input A12 – ADC (not available on devices without ADC or package options PW, RGE) Comparator_D input CD12 (not available on package options PW, RGE)
P3.1/A13/CD13	5	N/A	9	N/A	I/O	General-purpose digital I/O with port interrupt and wake up from LPMx.5 (not available on package options PW, RGE) Analog input A13 – ADC (not available on devices without ADC or package options PW, RGE) Comparator_D input CD13 (not available on package options PW, RGE)
P3.2/A14/CD14	6	N/A	10	N/A	I/O	General-purpose digital I/O with port interrupt and wake up from LPMx.5 (not available on package options PW, RGE) Analog input A14 – ADC (not available on devices without ADC or package options PW, RGE) Comparator_D input CD14 (not available on package options PW, RGE)
P3.3/A15/CD15	7	N/A	11	N/A	I/O	General-purpose digital I/O with port interrupt and wake up from LPMx.5 (not available on package options PW, RGE) Analog input A15 – ADC (not available on devices without ADC or package options PW, RGE) Comparator_D input CD15 (not available on package options PW, RGE)
P1.3/TA1.2/UCB0STE/ A3/CD3	8	4	12	8	I/O	General-purpose digital I/O with port interrupt and wake up from LPMx.5 TA1 CCR2 capture: CCI2A input, compare: Out2 Slave transmit enable – eUSCI_B0 SPI mode Analog input A3 – ADC (not available on devices without ADC) Comparator_D input CD3
P1.4/TB0.1/UCA0STE/ A4/CD4	9	5	13	9	I/O	General-purpose digital I/O with port interrupt and wake up from LPMx.5 TB0 CCR1 capture: CCI1A input, compare: Out1 Slave transmit enable – eUSCI_A0 SPI mode Analog input A4 – ADC (not available on devices without ADC) Comparator_D input CD4
P1.5/TB0.2/UCA0CLK/ A5/CD5	10	6	14	10	I/O	General-purpose digital I/O with port interrupt and wake up from LPMx.5 TB0 CCR2 capture: CCI2A input, compare: Out2 Clock signal input – eUSCI_B0 SPI slave mode; Clock signal output – eUSCI_B0 SPI master mode Analog input A5 – ADC (not available on devices without ADC) Comparator_D input CD5

(1) I = input, O = output, N/A = not available

Table 3. TERMINAL FUNCTIONS (continued)

TERMINAL					I/O ⁽¹⁾	DESCRIPTION
NAME	NO.					
	RH A	RG E	DA	PW		
PJ.0/TDO/TB0OUTH/ SMCLK/CD6	11	7	15	11	I/O	General-purpose digital I/O Test data output port Switch all PWM outputs high impedance input – TB0 SMCLK output Comparator_D input CD6
PJ.1/TDI/TCLK/TB1OUTH/ MCLK/CD7	12	8	16	12	I/O	General-purpose digital I/O Test data input or test clock input Switch all PWM outputs high impedance input – TB1 (not available on devices without TB1) MCLK output Comparator_D input CD7
PJ.2/TMS/TB2OUTH/ ACLK/CD8	13	9	17	13	I/O	General-purpose digital I/O Test mode select Switch all PWM outputs high impedance input – TB2 (not available on devices without TB2) ACLK output Comparator_D input CD8
PJ.3/TCK/CD9	14	10	18	14	I/O	General-purpose digital I/O Test clock Comparator_D input CD9
P4.0/TB2.0	15	N/A	N/A	N/A	I/O	General-purpose digital I/O with port interrupt and wake up from LPMx.5 (not available on package options PW, RGE) TB2 CCR0 capture: CCI0B input, compare: Out0 (not available on devices without TB2 or package options DA, PW, RGE)
P4.1	16	N/A	N/A	N/A	I/O	General-purpose digital I/O with port interrupt and wake up from LPMx.5 (not available on package options DA, PW, RGE)
P2.5/TB0.0/UCA1TXD/ UCA1SIMO	17	N/A	19	15	I/O	General-purpose digital I/O with port interrupt and wake up from LPMx.5 TB0 CCR0 capture: CCI0A input, compare: Out0 Transmit data – eUSCI_A1 UART mode; Slave in, master out – eUSCI_A1 SPI mode (not available on devices without UCSI_A1)
P2.6/TB1.0/UCA1RXD/ UCA1SOMI	18	N/A	20	16	I/O	General-purpose digital I/O with port interrupt and wake up from LPMx.5 TB1 CCR0 capture: CCI0A input, compare: Out0 (not available on devices without TB1) Receive data – eUSCI_A1 UART mode; Slave out, master in – eUSCI_A1 SPI mode (not available on devices without UCSI_A1)
TEST/SBWTCK	19	11	21	17	I	Test mode pin – enable JTAG pins Spy-bi-wire input clock
$\overline{\text{RST}}$ /NMI/SBWDIO	20	12	22	18	I/O	Reset input active low Non-maskable interrupt input Spy-bi-wire data input/output
P2.0/TB2.0/UCA0TXD/ UCA0SIMO/TB0CLK/ACLK	21	13	23	19	I/O	General-purpose digital I/O with port interrupt and wake up from LPMx.5 TB2 CCR0 capture: CCI0A input, compare: Out0 (not available on devices without TB2) Transmit data – eUSCI_A0 UART mode; Slave in, master out – eUSCI_A0 SPI mode TB0 clock input ACLK output
P2.1/TB2.1/UCA0RXD/ UCA0SOMI/TB0.0	22	14	24	20	I/O	General-purpose digital I/O with port interrupt and wake up from LPMx.5 TB2 CCR1 capture: CCI1A input, compare: Out1 (not available on devices without TB2) Receive data – eUSCI_A0 UART mode; Slave out, master in – eUSCI_A0 SPI mode; TB0 CCR0 capture: CCI0A input, compare: Out0

Table 3. TERMINAL FUNCTIONS (continued)

TERMINAL NAME	NO.				I/O ⁽¹⁾	DESCRIPTION
	RH A	RG E	DA	PW		
	P2.2/TB2.2/UCB0CLK/ TB1.0	23	15	25		
P3.4/TB1.1/TB2CLK/ SMCLK	24	N/A	26	N/A	I/O	General-purpose digital I/O with port interrupt and wake up from LPMx.5 (not available on package options PW, RGE) TB1 CCR1 capture: CCI1B input, compare: Out1 (not available on devices without TB1) TB2 clock input (not available on devices without TB2 or package options PW, RGE) SMCLK output (not available on package options PW, RGE)
P3.5/TB1.2/CDOUT	25	N/A	27	N/A	I/O	General-purpose digital I/O with port interrupt and wake up from LPMx.5 (not available on package options PW, RGE) TB1 CCR2 capture: CCI2B input, compare: Out2 (not available on devices without TB1) Comparator_D output (not available on package options PW, RGE)
P3.6/TB2.1/TB1CLK	26	N/A	28	N/A	I/O	General-purpose digital I/O with port interrupt and wake up from LPMx.5 (not available on package options PW, RGE) TB2 CCR1 capture: CCI1B input, compare: Out1 (not available on devices without TB2) TB1 clock input (not available on devices without TB1 or package options PW, RGE)
P3.7/TB2.2	27	N/A	29	N/A	I/O	General-purpose digital I/O with port interrupt and wake up from LPMx.5 (not available on package options PW, RGE) TB2 CCR2 capture: CCI2B input, compare: Out2 (not available on devices without TB2 or package options PW, RGE)
P1.6/TB1.1/UCB0SIMO/ UCB0SDA/TA0.0	28	16	30	22	I/O	General-purpose digital I/O with port interrupt and wake up from LPMx.5 TB1 CCR1 capture: CCI1A input, compare: Out1 (not available on devices without TB1) Slave in, master out – eUSCI_B0 SPI mode I2C data – eUSCI_B0 I2C mode TA0 CCR0 capture: CCI0A input, compare: Out0
P1.7/TB1.2/UCB0SOMI/ UCB0SCL/TA1.0	29	17	31	23	I/O	General-purpose digital I/O with port interrupt and wake up from LPMx.5 TB1 CCR2 capture: CCI2A input, compare: Out2 (not available on devices without TB1) Slave out, master in – eUSCI_B0 SPI mode I2C clock – eUSCI_B0 I2C mode TA1 CCR0 capture: CCI0A input, compare: Out0
VCORE ⁽²⁾	30	18	32	24		Regulated core power supply (internal usage only, no external current loading)
DVSS	31	19	33	25		Digital ground supply
DVCC	32	20	34	26		Digital power supply
P2.7	33	N/A	35	N/A	I/O	General-purpose digital I/O with port interrupt and wake up from LPMx.5 (not available on package options PW, RGE)
P2.3/TA0.0/UCA1STE/ A6/CD10	34	N/A	36	27	I/O	General-purpose digital I/O with port interrupt and wake up from LPMx.5 (not available on package options RGE) TA0 CCR0 capture: CCI0B input, compare: Out0 (not available on package options RGE) Slave transmit enable – eUSCI_A1 SPI mode (not available on devices without eUSCI_A1) Analog input A6 – ADC (not available on devices without ADC) Comparator_D input CD10 (not available on package options RGE)

(2) V_{CORE} is for internal usage only. No external current loading is possible. V_{CORE} should only be connected to the recommended capacitor value, C_{V_{CORE}}.

Table 3. TERMINAL FUNCTIONS (continued)

TERMINAL					I/O ⁽¹⁾	DESCRIPTION
NAME	NO.					
	RH A	RG E	DA	PW		
P2.4/TA1.0/UCA1CLK/ A7/CD11	35	N/A	37	28	I/O	General-purpose digital I/O with port interrupt and wake up from LPMx.5 (not available on package options RGE) TA1 CCR0 capture: CCI0B input, compare: Out0 (not available on package options RGE) Clock signal input – eUSCI_A1 SPI slave mode; Clock signal output – eUSCI_A1 SPI master mode (not available on devices without eUSCI_A1) Analog input A7 – ADC (not available on devices without ADC) Comparator_D input CD11 (not available on package options RGE)
AVSS	36	N/A	38	N/A		Analog ground supply
PJ.4/XIN	37	21	1	1	I/O	General-purpose digital I/O Input terminal for crystal oscillator XT1
PJ.5/XOUT	38	22	2	2	I/O	General-purpose digital I/O Output terminal of crystal oscillator XT1
AVSS	39	23	3	3		Analog ground supply
AVCC	40	24	4	4		Analog power supply
QFN Pad	Pad	Pad	N/A	N/A		QFN package pad. Connection to VSS recommended.

SHORT-FORM DESCRIPTION

CPU

The MSP430 CPU has a 16-bit RISC architecture that is highly transparent to the application. All operations, other than program-flow instructions, are performed as register operations in conjunction with seven addressing modes for source operand and four addressing modes for destination operand.

The CPU is integrated with 16 registers that provide reduced instruction execution time. The register-to-register operation execution time is one cycle of the CPU clock.

Four of the registers, R0 to R3, are dedicated as program counter, stack pointer, status register, and constant generator, respectively. The remaining registers are general-purpose registers.

Peripherals are connected to the CPU using data, address, and control buses, and can be handled with all instructions.

The instruction set consists of the original 51 instructions with three formats and seven address modes and additional instructions for the expanded address range. Each instruction can operate on word and byte data.

Operating Modes

The MSP430 has one active mode and seven software selectable low-power modes of operation. An interrupt event can wake up the device from low-power modes LPM0 through LPM4, service the request, and restore back to the low-power mode on return from the interrupt program. Low-power modes LPM3.5 and LPM4.5 disable the core supply to minimize power consumption.

The following eight operating modes can be configured by software:

- Active mode (AM)
 - All clocks are active
- Low-power mode 0 (LPM0)
 - CPU is disabled
 - ACLK active, MCLK disabled, SMCLK optionally active
 - Complete data retention
- Low-power mode 1 (LPM1)
 - CPU is disabled
 - ACLK active, MCLK disabled, SMCLK optionally active
 - DCO disabled
 - Complete data retention
- Low-power mode 2 (LPM2)
 - CPU is disabled
 - ACLK active, MCLK disabled, SMCLK optionally active
 - DCO disabled
 - Complete data retention
- Low-power mode 3 (LPM3)
 - CPU is disabled
 - ACLK active, MCLK and SMCLK disabled
 - DCO disabled
 - Complete data retention
- Low-power mode 4 (LPM4)
 - CPU is disabled
 - ACLK, MCLK, SMCLK disabled
 - Complete data retention
- Low-power mode 3.5 (LPM3.5)
 - RTC operation
 - Internal regulator disabled
 - No data retention
 - I/O pad state retention
 - Wake up from $\overline{\text{RST}}$, general purpose I/O, RTC events.
- Low-power mode 4.5 (LPM4.5)
 - Internal regulator disabled
 - No data retention
 - I/O pad state retention
 - Wake up from $\overline{\text{RST}}$ and general purpose I/O.

Interrupt Vector Addresses

The interrupt vectors and the power-up start address are located in the address range 0FFFFh to 0FF80h. The vector contains the 16-bit address of the appropriate interrupt-handler instruction sequence.

Table 4. Interrupt Sources, Flags, and Vectors

INTERRUPT SOURCE	INTERRUPT FLAG	SYSTEM INTERRUPT	WORD ADDRESS	PRIORITY
System Reset Power-Up, Brownout, Supply Supervisors External Reset \overline{RST} Watchdog Timeout (Watchdog mode) WDT, FRCTL MPU, CS, PMM Password Violation FRAM double bit error detection MPU segment violation Software POR, BOR	SVSLIFG, SVSHIFG PMMRSTIFG WDTIFG WDTPW, FRCTLPW, MPUPW, CSPW, PMMPW DBDIFG MPUSEGIIFG, MPUSEG1IFG, MPUSEG2IFG, MPUSEG3IFG PMMPORIFG, PMMBORIFG (SYSRSTIV) ^{(1) (2)}	Reset	0FFFEh	63, highest
System NMI Vacant Memory Access JTAG Mailbox FRAM access time error Access violation FRAM single, double bit error detection MPU segment violation	VMAIFG JMBNIFG, JMBOUTIFG ACCTIMIFG ACCVIFG SBDIFG, DBDIFG MPUSEGIIFG, MPUSEG1IFG, MPUSEG2IFG, MPUSEG3IFG (SYSSNIV) ⁽¹⁾	(Non)maskable	0FFFCh	62
User NMI External NMI Oscillator Fault	NMIIIFG, OFIFG (SYSUNIV) ^{(1) (2)}	(Non)maskable	0FFFAh	61
Comparator_D	Comparator_D interrupt flags (CBIV) ^{(1) (3)}	Maskable	0FFF8h	60
TB0	TB0CCR0 CCIFG0 ⁽³⁾	Maskable	0FFF6h	59
TB0	TB0CCR1 CCIFG1 to TB0CCR2 CCIFG2, TB0IFG (TB0IV) ^{(1) (3)}	Maskable	0FFF4h	58
Watchdog Timer (Interval Timer Mode)	WDTIFG	Maskable	0FFF2h	57
eUSCI_A0 Receive/Transmit	UCA0RXIFG, UCA0TXIFG (SPI mode) UCA0STTIFG, UCA0XCPTIFG, UCA0RXIFG, UCA0TXIFG (UART mode) (UCA0IV) ^{(1) (3)}	Maskable	0FFF0h	56
eUSCI_B0 Receive/Transmit	UCB0STTIFG, UCB0XCPTIFG, UCB0RXIFG, UCB0TXIFG (SPI mode) UCB0ALIFG, UCB0NACKIFG, UCB0STTIFG, UCB0STPIFG, UCB0RXIFG0, UCB0TXIFG0, UCB0RXIFG1, UCB0TXIFG1, UCB0RXIFG2, UCB0TXIFG2, UCB0RXIFG3, UCB0TXIFG3, UCB0CNTIFG, UCB0BIT9IFG (I2C mode) (UCAB0IV) ^{(1) (3)}	Maskable	0FFEEh	55
ADC10_B	ADC10OVIFG, ADC10TOVIFG, ADC10HIIFG, ADC10LOIFG ADC10INIFG, ADC10IFG0 (ADC10IV) ^{(1) (3) (4)}	Maskable	0FFECCh	54
TA0	TA0CCR0 CCIFG0 ⁽³⁾	Maskable	0FFEAh	53
TA0	TA0CCR1 CCIFG1 to TA0CCR2 CCIFG2, TA0IFG (TA0IV) ^{(1) (3)}	Maskable	0FFE8h	52

(1) Multiple source flags

(2) A reset is generated if the CPU tries to fetch instructions from within peripheral space or vacant memory space.

(Non)maskable: the individual interrupt-enable bit can disable an interrupt event, but the general-interrupt enable cannot disable it.

(3) Interrupt flags are located in the module.

(4) Only on devices with ADC, otherwise reserved.

Table 4. Interrupt Sources, Flags, and Vectors (continued)

INTERRUPT SOURCE	INTERRUPT FLAG	SYSTEM INTERRUPT	WORD ADDRESS	PRIORITY
eUSCI_A1 Receive/Transmit	UCA1RXIFG, UCA1TXIFG (SPI mode) UCA1STTIFG, UCA1TXCPTIFG, UCA1RXIFG, UXA1TXIFG (UART mode) (UCA1IV) ^{(1) (3)}	Maskable	0FFE6h	51
DMA	DMA0IFG, DMA1IFG, DMA2IFG (DMAIV) ^{(1) (3)}	Maskable	0FFE4h	50
TA1	TA1CCR0 CCIFG0 ⁽³⁾	Maskable	0FFE2h	49
TA1	TA1CCR1 CCIFG1 to TA1CCR2 CCIFG2, TA1IFG (TA1IV) ^{(1) (3)}	Maskable	0FFE0h	48
I/O Port P1	P1IFG.0 to P1IFG.7 (P1IV) ^{(1) (3)}	Maskable	0FFDEh	47
TB1	TB1CCR0 CCIFG0 ⁽³⁾	Maskable	0FFDCh	46
TB1	TB1CCR1 CCIFG1 to TB1CCR2 CCIFG2, TB1IFG (TB1IV) ^{(1) (3)}	Maskable	0FFDAh	45
I/O Port P2	P2IFG.0 to P2IFG.7 (P2IV) ^{(1) (3)}	Maskable	0FFD8h	44
TB2	TB2CCR0 CCIFG0 ⁽³⁾	Maskable	0FFD6h	43
TB2	TB2CCR1 CCIFG1 to TB2CCR2 CCIFG2, TB2IFG (TB2IV) ^{(1) (3)}	Maskable	0FFD4h	42
I/O Port P3	P3IFG.0 to P3IFG.7 (P3IV) ^{(5) (6)}	Maskable	0FFD2h	41
I/O Port P4	P4IFG.0 to P4IFG.2 (P4IV) ^{(5) (6)}	Maskable	0FFD0h	40
RTC_B	RTCRDYIFG, RTCTEVIFG, RTCAIFG, RT0PSIFG, RT1PSIFG, RTCOFIFG (RTCIV) ^{(5) (6)}	Maskable	0FFCEh	39
Reserved	Reserved ⁽⁷⁾		0FFCCh : 0FF80h	38 : 0, lowest

(5) Multiple source flags

(6) Interrupt flags are located in the module.

(7) Reserved interrupt vectors at addresses are not used in this device and can be used for regular program code if necessary. To maintain compatibility with other devices, it is recommended to reserve these locations.

PRODUCT PREVIEW

Memory Organization

Table 5. Memory Organization^{(1) (2)}

		MSP430FR5726 MSP430FR5727 MSP430FR5728 MSP430FR5729 MSP430FR5736 MSP430FR5737 MSP430FR5738 MSP430FR5739	MSP430FR5722 MSP430FR5723 MSP430FR5724 MSP430FR5725 MSP430FR5732 MSP430FR5733 MSP430FR5734 MSP430FR5735	MSP430FR5720 MSP430FR5721 MSP430FR5730 MSP430FR5731
Memory (FRAM) Main: interrupt vectors Main: code memory	Total Size	15.5 KB 00FFFFh–00FF80h 00FF7Fh–00C200h	8.0 KB 00FFFFh–00FF80h 00FF7Fh–00E000h	4 KB 00FFFFh–00FF80h 00FF7Fh–00F000h
RAM		1 KB 001FFFh–001C00h	1 KB 001FFFh–001C00h	0.5 KB 001DFFh–001C00h
Device Descriptor Info (TLV) (FRAM)		128 B 001A7Fh–001A00h	128 B 001A7Fh–001A00h	128 B 001A7Fh–001A00h
Information memory (FRAM)	N/A	0019FFh–001980h Address space mirrored to Info A	0019FFh–001980h Address space mirrored to Info A	0019FFh–001980h Address space mirrored to Info B
	N/A	00197Fh–001900h Address space mirrored to Info B	00197Fh–001900h Address space mirrored to Info B	00197Fh–001900h Address space mirrored to Info A
	Info A	128 B 0018FFh–001880h	128 B 0018FFh–001880h	128 B 0018FFh–001880h
	Info B	128 B 00187Fh–001800h	128 B 00187Fh–001800h	128 B 00187Fh–001800h
Bootstrap loader (BSL) memory (ROM)	BSL 3	512 B 0017FFh–001600h	512 B 0017FFh–001600h	512 B 0017FFh–001600h
	BSL 2	512 B 0015FFh–001400h	512 B 0015FFh–001400h	512 B 0015FFh–001400h
	BSL 1	512 B 0013FFh–001200h	512 B 0013FFh–001200h	512 B 0013FFh–001200h
	BSL 0	512 B 0011FFh–001000h	512 B 0011FFh–001000h	512 B 0011FFh–001000h
Peripherals	Size	4 KB 000FFFh–0h	4 KB 000FFFh–0h	4 KB 000FFFh–0h

(1) N/A = Not available.

(2) All address space not listed above is considered vacant memory.

Bootstrap Loader (BSL)

The BSL enables users to program the FRAM or RAM using a UART serial interface. Access to the device memory via the BSL is protected by an user-defined password. Usage of the BSL requires four pins as shown in [Table 6](#). BSL entry requires a specific entry sequence on the $\overline{\text{RST}}/\text{NMI}/\text{SBWTDIO}$ and $\text{TEST}/\text{SBWTCK}$ pins. For complete description of the features of the BSL and its implementation, see the *MSP430 Memory Programming User's Guide*, literature number [SLAU265](#).

Table 6. BSL Pin Requirements and Functions

DEVICE SIGNAL	BSL FUNCTION
$\overline{\text{RST}}/\text{NMI}/\text{SBWTDIO}$	Entry sequence signal
$\text{TEST}/\text{SBWTCK}$	Entry sequence signal
P2.0	Data transmit
P2.1	Data receive
VCC	Power supply
VSS	Ground supply

JTAG Operation

JTAG Standard Interface

The MSP430 family supports the standard JTAG interface which requires four signals for sending and receiving data. The JTAG signals are shared with general-purpose I/O. The $\text{TEST}/\text{SBWTCK}$ pin is used to enable the JTAG signals. In addition to these signals, the $\overline{\text{RST}}/\text{NMI}/\text{SBWTDIO}$ is required to interface with MSP430 development tools and device programmers. The JTAG pin requirements are shown in [Table 7](#). For further details on interfacing to development tools and device programmers, see the *MSP430 Hardware Tools User's Guide*, literature number [SLAU278](#).

Table 7. JTAG Pin Requirements and Functions

DEVICE SIGNAL	Direction	FUNCTION
PJ.3/TCK	IN	JTAG clock input
PJ.2/TMS	IN	JTAG state control
PJ.1/TDI/TCLK	IN	JTAG data input/TCLK input
PJ.0/TDO	OUT	JTAG data output
$\text{TEST}/\text{SBWTCK}$	IN	Enable JTAG pins
$\overline{\text{RST}}/\text{NMI}/\text{SBWTDIO}$	IN	External reset
VCC		Power supply
VSS		Ground supply

Spy-Bi-Wire Interface

In addition to the standard JTAG interface, the MSP430 family supports the two wire Spy-Bi-Wire interface. Spy-Bi-Wire can be used to interface with MSP430 development tools and device programmers. The Spy-Bi-Wire interface pin requirements are shown in [Table 8](#). For further details on interfacing to development tools and device programmers, see the *MSP430 Hardware Tools User's Guide*, literature number [SLAU278](#).

Table 8. Spy-Bi-Wire Pin Requirements and Functions

DEVICE SIGNAL	Direction	FUNCTION
$\text{TEST}/\text{SBWTCK}$	IN	Spy-Bi-Wire clock input
$\overline{\text{RST}}/\text{NMI}/\text{SBWTDIO}$	IN, OUT	Spy-Bi-Wire data input/output
VCC		Power supply
VSS		Ground supply

FRAM

The FRAM can be programmed via the JTAG port, Spy-Bi-Wire (SBW), the BSL, or in-system by the CPU. Features of the FRAM include:

- Low power, ultra fast write non-volatile memory.
- Byte and word access capability.
- Programmable and automated wait state generation.
- Error Correction Coding (ECC) with single bit detection and correction, double bit detection.

Memory Protection Unit (MPU)

The FRAM can be protected from inadvertent CPU execution or write access by the MPU. Features of the MPU include:

- Main memory partitioning programmable up to three segments.
- Each segment's (main and information memory) access rights can be individually selected.
- Access violation flags with interrupt capability for easy servicing of access violations.

Peripherals

Peripherals are connected to the CPU through data, address, and control buses and can be handled using all instructions. For complete module descriptions, see the *MSP430FR57xx Family User's Guide*, literature number [SLAU272](#).

Digital I/O

There are up to four 8-bit I/O ports implemented:

- All individual I/O bits are independently programmable.
- Any combination of input, output, and interrupt conditions is possible.
- Programmable pullup or pulldown on all ports.
- Edge-selectable interrupt and LPM3.5 and LPM4.5 wake up input capability is available for all ports.
- Read/write access to port-control registers is supported by all instructions.
- Ports can be accessed byte-wise or word-wise in pairs.

Oscillator and Clock System (CS)

The clock system includes support for a 32 kHz watch crystal oscillator XT1 (LF mode), an internal very-low-power low-frequency oscillator (VLO), an integrated internal digitally-controlled oscillator (DCO), and a high-frequency crystal oscillator XT1 (HF mode). The clock system module is designed to meet the requirements of both low system cost and low-power consumption. A fail-safe mechanism exists for all crystal sources. The clock system module provides the following clock signals:

- Auxiliary clock (ACLK), sourced from a 32 kHz watch crystal (XT1 LF mode), a high-frequency crystal (XT1 HF mode), the internal low-frequency oscillator (VLO), or the internal digitally-controlled oscillator DCO.
- Main clock (MCLK), the system clock used by the CPU. MCLK can be sourced by same sources made available to ACLK.
- Sub-Main clock (SMCLK), the subsystem clock used by the peripheral modules. SMCLK can be sourced by same sources made available to ACLK.

Power Management Module (PMM)

The PMM includes an integrated voltage regulator that supplies the core voltage to the device. The PMM also includes supply voltage supervisor (SVS), as well as brownout protection. The brownout circuit is implemented to provide the proper internal reset signal to the device during power-on and power-off. The SVS circuitry detects if the supply voltage drops a safe level and below a user-selectable supports both supply voltage supervision. SVS circuitry is available on the primary and core supplies.

Hardware Multiplier

The multiplication operation is supported by a dedicated peripheral module. The module performs operations with 32-bit, 24-bit, 16-bit, and 8-bit operands. The module is capable of supporting signed and unsigned multiplication as well as signed and unsigned multiply and accumulate operations.

Real-Time Clock (RTC_B)

The RTC_B module contains an integrated real-time clock (RTC) (calendar mode). Calendar mode integrates an internal calendar which compensates for months with less than 31 days and includes leap year correction. The RTC_B also supports flexible alarm functions and offset-calibration hardware. RTC operation is available in LPM3.5 modes to minimize power consumption.

Watchdog Timer (WDT_A)

The primary function of the watchdog timer (WDT_A) module is to perform a controlled system restart after a software problem occurs. If the selected time interval expires, a system reset is generated. If the watchdog function is not needed in an application, the module can be configured as an interval timer and can generate interrupts at selected time intervals.

System Module (SYS)

The SYS module handles many of the system functions within the device. These include power on reset and power up clear handling, NMI source selection and management, reset interrupt vector generators, boot strap loader entry mechanisms, as well as, configuration management (device descriptors). It also includes a data exchange mechanism via JTAG called a JTAG mailbox that can be used in the application.

Table 9. System Module Interrupt Vector Registers

INTERRUPT VECTOR REGISTER	ADDRESS	INTERRUPT EVENT	VALUE	PRIORITY
SYSRSTIV , System Reset	019Eh	No interrupt pending	00h	
		Brownout (BOR)	02h	Highest
		RSTIFG $\overline{\text{RST}}$ /NMI (BOR)	04h	
		PMMSWBOR software BOR (BOR)	06h	
		LPMx.5 wake up (BOR)	08h	
		Security violation (BOR)	0Ah	
		SVSLIFG SVSL event (BOR)	0Ch	
		SVSHIFG SVSH event (BOR)	0Eh	
		Reserved	10h	
		Reserved	12h	
		PMMSWPOR software POR (POR)	14h	
		WDTIFG watchdog timeout (PUC)	16h	
		WDTPW password violation (PUC)	18h	
		FRCTLPW password violation (PUC)	1Ah	
		DBDIFG FRAM double bit error (PUC)	1Ch	
		Peripheral area fetch (PUC)	1Eh	
		PMMPW PMM password violation (PUC)	20h	
		MPUPW MPU password violation (PUC)	22h	
		CSPW CS password violation (PUC)	24h	
		MPUSEGIIFG information memory segment violation (PUC)	26h	
		MPUSEG1IFG segment 1 memory violation (PUC)	28h	
		MPUSEG2IFG segment 2 memory violation (PUC)	2Ah	
		MPUSEG3IFG segment 3 memory violation (PUC)	2Ch	
Reserved	2Eh			
Reserved	30h to 3Eh	Lowest		
SYSSNIV , System NMI	019Ch	No interrupt pending	00h	
		DBDIFG FRAM double bit error	02h	Highest
		ACCTIMIFG access time error	04h	
		MPUSEGIIFG information memory segment violation	06h	
		MPUSEG1IFG segment 1 memory violation	08h	
		MPUSEG2IFG segment 2 memory violation	0Ah	
		MPUSEG3IFG segment 3 memory violation	0Ch	
		ACCVIFG access violation	0Eh	
		VMAIFG Vacant memory access	10h	
		JMBINIFG JTAG mailbox input	12h	
		JMBOUTIFG JTAG mailbox output	14h	
		SBDIFG FRAM single bit error	16h	
		Reserved	18h to 1Eh	Lowest
		SYSUNIV, User NMI	019Ah	No interrupt pending
NMIFG NMI pin	02h			Highest
OFIFG oscillator fault	04h			
Reserved	06h			
Reserved	08h			
Reserved	0Ah to 1Eh			Lowest

PRODUCT PREVIEW

DMA Controller

The DMA controller allows movement of data from one memory address to another without CPU intervention. For example, the DMA controller can be used to move data from the ADC10_B conversion memory to RAM. Using the DMA controller can increase the throughput of peripheral modules. The DMA controller reduces system power consumption by allowing the CPU to remain in sleep mode, without having to awaken to move data to or from a peripheral.

Table 10. DMA Trigger Assignments⁽¹⁾

Trigger	Channel 0	Channel 1	Channel 2
0	DMAREQ	DMAREQ	DMAREQ
1	TA0CCR0 CCIFG	TA0CCR0 CCIFG	TA0CCR0 CCIFG
2	TA0CCR2 CCIFG	TA0CCR2 CCIFG	TA0CCR2 CCIFG
3	TA1CCR0 CCIFG	TA1CCR0 CCIFG	TA1CCR0 CCIFG
4	TA1CCR2 CCIFG	TA1CCR2 CCIFG	TA1CCR2 CCIFG
5	Reserved	Reserved	Reserved
6	Reserved	Reserved	Reserved
7	TB0CCR0 CCIFG	TB0CCR0 CCIFG	TB0CCR0 CCIFG
8	TB0CCR2 CCIFG	TB0CCR2 CCIFG	TB0CCR2 CCIFG
9	TB1CCR0 CCIFG ⁽²⁾	TB1CCR0 CCIFG ⁽²⁾	TB1CCR0 CCIFG ⁽²⁾
10	TB1CCR2 CCIFG ⁽²⁾	TB1CCR2 CCIFG ⁽²⁾	TB1CCR2 CCIFG ⁽²⁾
11	TB2CCR0 CCIFG ⁽³⁾	TB2CCR0 CCIFG ⁽³⁾	TB2CCR0 CCIFG ⁽³⁾
12	TB2CCR2 CCIFG ⁽³⁾	TB2CCR2 CCIFG ⁽³⁾	TB2CCR2 CCIFG ⁽³⁾
13	Reserved	Reserved	Reserved
14	UCA0RXIFG	UCA0RXIFG	UCA0RXIFG
15	UCA0TXIFG	UCA0TXIFG	UCA0TXIFG
16	UCA1RXIFG ⁽⁴⁾	UCA1RXIFG ⁽⁴⁾	UCA1RXIFG ⁽⁴⁾
17	UCA1TXIFG ⁽⁴⁾	UCA1TXIFG ⁽⁴⁾	UCA1TXIFG ⁽⁴⁾
18	UCB0RXIFG0	UCB0RXIFG0	UCB0RXIFG0
19	UCB0TXIFG0	UCB0TXIFG0	UCB0TXIFG0
20	UCB0RXIFG1	UCB0RXIFG1	UCB0RXIFG1
21	UCB0TXIFG1	UCB0TXIFG1	UCB0TXIFG1
22	UCB0RXIFG2	UCB0RXIFG2	UCB0RXIFG2
23	UCB0TXIFG2	UCB0TXIFG2	UCB0TXIFG2
24	UCB0RXIFG3	UCB0RXIFG3	UCB0RXIFG3
25	UCB0TXIFG3	UCB0TXIFG3	UCB0TXIFG3
26	ADC10IFGx ⁽⁵⁾	ADC10IFGx ⁽⁵⁾	ADC10IFGx ⁽⁵⁾
27	Reserved	Reserved	Reserved
28	Reserved	Reserved	Reserved
29	MPY ready	MPY ready	MPY ready
30	DMA2IFG	DMA0IFG	DMA1IFG
31	DMAE0	DMAE0	DMAE0

- (1) If a reserved trigger source is selected, no trigger is generated.
- (2) Only on devices with TB1, otherwise reserved.
- (3) Only on devices with TB2, otherwise reserved.
- (4) Only on devices with eUSCI_A1, otherwise reserved.
- (5) Only on devices with ADC. Reserved on devices without ADC.

Enhanced Universal Serial Communication Interface (eUSCI)

The eUSCI modules are used for serial data communication. The eUSCI module supports synchronous communication protocols such as SPI (3 or 4 pin) and I²C, and asynchronous communication protocols such as UART, enhanced UART with automatic baudrate detection, and IrDA. Each eUSCI module contains two portions, A and B.

The eUSCI_An module provides support for SPI (3 pin or 4 pin), UART, enhanced UART, or IrDA.

The eUSCI_Bn module provides support for SPI (3 pin or 4 pin) or I2C.

The MSP430FR572x and MSP430FR573x series include one or two eUSCI_An modules (eUSCI_A0, eUSCI_A1) and one eUSCI_Bn module (eUSCI_B).

TA0, TA1

TA0 and TA1 are 16-bit timers/counters (Timer_A type) with three capture/compare registers each. Each can support multiple capture/compares, PWM outputs, and interval timing. Each has extensive interrupt capabilities. Interrupts may be generated from the counter on overflow conditions and from each of the capture/compare registers.

Table 11. TA0 Signal Connections

INPUT PIN NUMBER				DEVICE INPUT SIGNAL	MODULE INPUT SIGNAL	MODULE BLOCK	MODULE OUTPUT SIGNAL	DEVICE OUTPUT SIGNAL	OUTPUT PIN NUMBER			
RHA	RGE	DA	PW						RHA	RGE	DA	PW
3-P1.2	3-P1.2	7-P1.2	7-P1.2	TA0CLK	TACLK	Timer	N/A	N/A				
				ACLK (internal)	ACLK							
				SMCLK (internal)	SMCLK							
3-P1.2	3-P1.2	7-P1.2	7-P1.2	TA0CLK	TACLK	CCR0	TA0	TA0.0				
28-P1.6	16-1.6	30-P1.6	22-P1.6	TA0.0	CCI0A				28-P1.6	16-1.6	30-P1.6	22-P1.6
34-P2.3	N/A	36-P2.3	27-P2.3	TA0.0	CCI0B				34-P2.3	N/A	36-P2.3	27-P2.3
				DV _{SS}	GND							
				DV _{CC}	V _{CC}							
1-P1.0	1-P1.0	5-P1.0	5-P1.0	TA0.1	CCI1A	CCR1	TA1	TA0.1	1-P1.0	1-P1.0	5-P1.0	5-P1.0
				CDOUT (internal)	CCI1B				ADC10 (internal) ⁽¹⁾	ADC10 (internal) ⁽¹⁾	ADC10 (internal) ⁽¹⁾	ADC10 (internal) ⁽¹⁾
									ADC10SH	ADC10SH	ADC10SH	ADC10SH
									Sx = {1}	Sx = {1}	Sx = {1}	Sx = {1}
				DV _{SS}	GND							
				DV _{CC}	V _{CC}							
2-P1.1	2-P1.1	6-P1.1	6-P1.1	TA0.2	CCI2A	CCR2	TA2	TA0.2	2-P1.1	2-P1.1	6-P1.1	6-P1.1
				ACLK (internal)	CCI2B							
				DV _{SS}	GND							
				DV _{CC}	V _{CC}							

(1) Only on devices with ADC.

Table 12. TA1 Signal Connections

INPUT PIN NUMBER				DEVICE INPUT SIGNAL	MODULE INPUT SIGNAL	MODULE BLOCK	MODULE OUTPUT SIGNAL	DEVICE OUTPUT SIGNAL	OUTPUT PIN NUMBER			
RHA	RGE	DA	PW						RHA	RGE	DA	PW
2-P1.1	2-P1.1	6-P1.1	6-P1.1	TA1CLK	TACLK	Timer	N/A	N/A				
				ACLK (internal)	ACLK							
				SMCLK (internal)	SMCLK							
2-P1.1	2-P1.1	6-P1.1	6-P1.1	TA1CLK	$\overline{\text{TACLK}}$							
29-P1.7	17-P1.7	31-P1.7	23-P1.7	TA1.0	CCI0A	CCR0	TA0	TA1.0	29-P1.7	17-P1.7	31-P1.7	23-P1.7
35-P2.4	N/A	37-P2.4	28-P2.4	TA1.0	CCI0B				35-P2.4	N/A	37-P2.4	28-P2.4
				DV _{SS}	GND							
				DV _{CC}	V _{CC}							
3-P1.2	3-P1.2	7-P1.2	7-P1.2	TA1.1	CCI1A	CCR1	TA1	TA1.1	3-P1.2	3-P1.2	7-P1.2	7-P1.2
				CDOUT (internal)	CCI1B							
				DV _{SS}	GND							
				DV _{CC}	V _{CC}							
8-P1.3	4-P1.3	12-P1.3	8-P1.3	TA1.2	CCI2A	CCR2	TA2	TA1.2	8-P1.3	4-P1.3	12-P1.3	8-P1.3
				ACLK (internal)	CCI2B							
				DV _{SS}	GND							
				DV _{CC}	V _{CC}							

TB0, TB1, TB2

TB0, TB1, TB2 are 16-bit timers/counters (Timer_B type) with three capture/compare registers each. Each can support multiple capture/compares, PWM outputs, and interval timing. Each has extensive interrupt capabilities. Interrupts may be generated from the counter on overflow conditions and from each of the capture/compare registers.

Table 13. TB0 Signal Connections

INPUT PIN NUMBER				DEVICE INPUT SIGNAL	MODULE INPUT SIGNAL	MODULE BLOCK	MODULE OUTPUT SIGNAL	DEVICE OUTPUT SIGNAL	OUTPUT PIN NUMBER			
RHA	RGE	DA	PW						RHA	RGE	DA	PW
21-P2.0	13-P2.0	23-P2.0	19-P2.0	TB0CLK	TBCLK	Timer	N/A	N/A				
				ACLK (internal)	ACLK							
				SMCLK (internal)	SMCLK							
21-P2.0	13-P2.0	23-P2.0	19-P2.0	TB0CLK	$\overline{\text{TBCLK}}$	CCR0	TB0	TB0.0	22-P2.1	14-P2.1	24-P2.1	20-P2.1
22-P2.1	14-P2.1	24-P2.1	20-P2.1	TB0.0	CCI0A				17-P2.5	N/A	19-P2.5	15-P2.5
17-P2.5	N/A	19-P2.5	15-P2.5	TB0.0	CCI0B				ADC10 (internal) ⁽¹⁾	ADC10 (internal) ⁽¹⁾	ADC10 (internal) ⁽¹⁾	ADC10 (internal) ⁽¹⁾
				DV _{SS}	GND				ADC10SH Sx = {2}	ADC10SH Sx = {2}	ADC10SH Sx = {2}	ADC10SH Sx = {2}
				DV _{CC}	V _{CC}							
9-P1.4	5-P1.4	13-P1.4	9-P1.4	TB0.1	CCI1A	CCR1	TB1	TB0.1	9-P1.4	5-P1.4	13-P1.4	9-P1.4
				CDOUT (internal)	CCI1B				ADC10 (internal) ⁽¹⁾	ADC10 (internal) ⁽¹⁾	ADC10 (internal) ⁽¹⁾	ADC10 (internal) ⁽¹⁾
				DV _{SS}	GND				ADC10SH Sx = {3}	ADC10SH Sx = {3}	ADC10SH Sx = {3}	ADC10SH Sx = {3}
				DV _{CC}	V _{CC}							
10-P1.5	6-P1.5	14-P1.5	19-P1.5	TB0.2	CCI2A	CCR2	TB2	TB0.2	10-P1.5	6-P1.5	14-P1.5	19-P1.5
				ACLK (internal)	CCI2B							
				DV _{SS}	GND							
				DV _{CC}	V _{CC}							

(1) Only on devices with ADC.

Table 14. TB1 Signal Connections⁽¹⁾

INPUT PIN NUMBER				DEVICE INPUT SIGNAL	MODULE INPUT SIGNAL	MODULE BLOCK	MODULE OUTPUT SIGNAL	DEVICE OUTPUT SIGNAL	OUTPUT PIN NUMBER			
RHA	RGE	DA	PW						RHA	RGE	DA	PW
26-P3.6	N/A (DV _{SS})	28-P3.6	N/A (DV _{SS})	TB1CLK	TBCLK	Timer	N/A	N/A				
				ACLK (internal)	ACLK							
				SMCLK (internal)	SMCLK							
26-P3.6	N/A (DV _{SS})	28-P3.6	N/A (DV _{SS})	TB1CLK	$\overline{\text{TBCLK}}$							
23-P2.2	N/A (DV _{SS})	25-P2.2	N/A (DV _{SS})	TB1.0	CCI0A	CCR0	TB0	TB1.0	23-P2.2	N/A	25-P2.2	N/A
18-P2.6	N/A (DV _{SS})	20-P2.6	N/A (DV _{SS})	TB1.0	CCI0B				18-P2.6	N/A	20-P2.6	N/A
				DV _{SS}	GND							
				DV _{CC}	V _{CC}							
28-P1.6	N/A (DV _{SS})	30-P1.6	N/A (DV _{SS})	TB1.1	CCI1A	CCR1	TB1	TB1.1	28-P1.6	N/A	30-P1.6	N/A
24-P3.4	N/A (DV _{SS})	26-P3.4	N/A (DV _{SS})	TB1.1	CCI1B				24-P3.4	N/A	26-P3.4	N/A
				DV _{SS}	GND							
				DV _{CC}	V _{CC}							
29-P1.7	N/A (DV _{SS})	31-P1.7	N/A (DV _{SS})	TB1.2	CCI2A	CCR2	TB2	TB1.2	29-P1.7	N/A	31-P1.7	N/A
25-P3.5	N/A (DV _{SS})	27-P3.5	N/A (DV _{SS})	TB1.2	CCI2B				25-P3.5	N/A	27-P3.5	N/A
				DV _{SS}	GND							
				DV _{CC}	V _{CC}							

(1) TB1 is not present on all device types.

Table 15. TB2 Signal Connections⁽¹⁾

INPUT PIN NUMBER				DEVICE INPUT SIGNAL	MODULE INPUT SIGNAL	MODULE BLOCK	MODULE OUTPUT SIGNAL	DEVICE OUTPUT SIGNAL	OUTPUT PIN NUMBER			
RHA	RGE	DA	PW						RHA	RGE	DA	PW
24-P3.4	N/A (DV _{SS})	26-P3.4	N/A (DV _{SS})	TB2CLK	TBCLK	Timer	N/A	N/A				
				ACLK (internal)	ACLK							
				SMCLK (internal)	SMCLK							
24-P3.4	N/A (DV _{SS})	26-P3.4	N/A (DV _{SS})	TB2CLK	$\overline{\text{TBCLK}}$							
21-P2.0	N/A (DV _{SS})	23-P2.0	N/A (DV _{SS})	TB2.0	CCI0A	CCR0	TB0	TB2.0	21-P2.0	N/A	23-P2.0	N/A
15-P4.0	N/A (DV _{SS})	N/A (DV _{SS})	N/A (DV _{SS})	TB2.0	CCI0B				15-P4.0	N/A	36-P4.0	N/A
				DV _{SS}	GND							
				DV _{CC}	V _{CC}							
22-P2.1	N/A (DV _{SS})	24-P2.1	N/A (DV _{SS})	TB2.1	CCI1A	CCR1	TB1	TB2.1	22-P2.1	N/A	24-P2.1	N/A
26-P3.6	N/A (DV _{SS})	28-P3.6	N/A (DV _{SS})	TB2.1	CCI1B				26-P3.6	N/A	28-P3.6	N/A
				DV _{SS}	GND							
				DV _{CC}	V _{CC}							
23-P2.2	N/A (DV _{SS})	25-P2.2	N/A (DV _{SS})	TB2.2	CCI2A	CCR2	TB2	TB2.2	23-P2.2	N/A	25-P2.2	N/A
27-P3.7	N/A (DV _{SS})	29-P3.7	N/A (DV _{SS})	TB2.2	CCI2B				27-P3.7	N/A	29-P3.7	N/A
				DV _{SS}	GND							
				DV _{CC}	V _{CC}							

(1) TB2 is not present on all device types.

ADC10_B

The ADC10_B module supports fast, 10-bit analog-to-digital conversions. The module implements a 10-bit SAR core, sample select control, reference generator and a conversion result buffer. A window comparator with a lower and upper limit allows CPU independent result monitoring with three window comparator interrupt flags.

Comparator_D

The primary function of the Comparator_D module is to support precision slope analog-to-digital conversions, battery voltage supervision, and monitoring of external analog signals.

CRC16

The CRC16 module produces a signature based on a sequence of entered data values and can be used for data checking purposes. The CRC16 module signature is based on the CRC-CCITT standard.

Shared Reference (REF)

The reference module (REF) is responsible for generation of all critical reference voltages that can be used by the various analog peripherals in the device.

Embedded Emulation Module (EEM)

The Embedded Emulation Module (EEM) supports real-time in-system debugging. The S version of the EEM implemented on all devices has the following features:

- Three hardware triggers/breakpoints on memory access
- One hardware trigger/breakpoint on CPU register write access
- Up to four hardware triggers can be combined to form complex triggers/breakpoints
- One cycle counter
- Clock control on module level

Peripheral File Map

Table 16. Peripherals

MODULE NAME	BASE ADDRESS	OFFSET ADDRESS RANGE
Special Functions (see Table 17)	0100h	000h - 01Fh
PMM (see Table 18)	0120h	000h - 010h
FRAM Control (see Table 19)	0140h	000h - 00Fh
CRC16 (see Table 20)	0150h	000h - 007h
Watchdog (see Table 21)	015Ch	000h - 001h
CS (see Table 22)	0160h	000h - 00Fh
SYS (see Table 23)	0180h	000h - 01Fh
Shared Reference (see Table 24)	01B0h	000h - 001h
Port P1/P2 (see Table 25)	0200h	000h - 01Fh
Port P3/P4 (see Table 26)	0220h	000h - 01Fh
Port PJ (see Table 27)	0320h	000h - 01Fh
TA0 (see Table 28)	0340h	000h - 02Fh
TA1 (see Table 29)	0380h	000h - 02Fh
TB0 (see Table 30)	03C0h	000h - 02Fh
TB1 (see Table 31)	0400h	000h - 02Fh
TB2 (see Table 32)	0440h	000h - 02Fh
Real Timer Clock (RTC_B) (see Table 33)	04A0h	000h - 01Fh
32-bit Hardware Multiplier (see Table 34)	04C0h	000h - 02Fh
DMA General Control (see Table 35)	0500h	000h - 00Fh
DMA Channel 0 (see Table 35)	0510h	000h - 00Ah
DMA Channel 1 (see Table 35)	0520h	000h - 00Ah
DMA Channel 2 (see Table 35)	0530h	000h - 00Ah
MPU Control (see Table 36)	05A0h	000h - 00Fh
eUSCI_A0 (see Table 37)	05C0h	000h - 01Fh
eUSCI_A1 (see Table 38)	05E0h	000h - 01Fh
eUSCI_B0 (see Table 39)	0640h	000h - 02Fh
ADC10_B (see Table 40)	0700h	000h - 03Fh
Comparator_D (see Table 41)	08C0h	000h - 00Fh

Table 17. Special Function Registers (Base Address: 0100h)

REGISTER DESCRIPTION	REGISTER	OFFSET
SFR interrupt enable	SFRIE1	00h
SFR interrupt flag	SFRIFG1	02h
SFR reset pin control	SFRRPCR	04h

Table 18. PMM Registers (Base Address: 0120h)

REGISTER DESCRIPTION	REGISTER	OFFSET
PMM Control 0	PMMCTL0	00h
PMM interrupt flags	PMMIFG	0Ah
PM5 Control 0	PM5CTL0	10h

Table 19. FRAM Control Registers (Base Address: 0140h)

REGISTER DESCRIPTION	REGISTER	OFFSET
FRAM control 0	FRCTLCTLO	00h
General control 0	GCCTL0	04h
General control 1	GCCTL1	06h

Table 20. CRC16 Registers (Base Address: 0150h)

REGISTER DESCRIPTION	REGISTER	OFFSET
CRC data input	CRC16DI	00h
CRC data input reverse byte	CRCDIRB	02h
CRC initialization and result	CRCINIRES	04h
CRC result reverse byte	CRCRESR	06h

Table 21. Watchdog Registers (Base Address: 015Ch)

REGISTER DESCRIPTION	REGISTER	OFFSET
Watchdog timer control	WDTCTL	00h

Table 22. CS Registers (Base Address: 0160h)

REGISTER DESCRIPTION	REGISTER	OFFSET
CS control 0	CSCTL0	00h
CS control 1	CSCTL1	02h
CS control 2	CSCTL2	04h
CS control 3	CSCTL3	06h
CS control 4	CSCTL4	08h
CS control 5	CSCTL5	0Ah
CS control 6	CSCTL6	0Ch

Table 23. SYS Registers (Base Address: 0180h)

REGISTER DESCRIPTION	REGISTER	OFFSET
System control	SYSCCTL	00h
Bootstrap loader configuration area	SYSBSLC	02h
JTAG mailbox control	SYSJMBC	06h
JTAG mailbox input 0	SYSJMBIO	08h
JTAG mailbox input 1	SYSJMBI1	0Ah
JTAG mailbox output 0	SYSJMBO0	0Ch
JTAG mailbox output 1	SYSJMBO1	0Eh
Bus Error vector generator	SYSBERRIV	18h
User NMI vector generator	SYSUNIV	1Ah
System NMI vector generator	SYSSNIV	1Ch
Reset vector generator	SYSRSTIV	1Eh

Table 24. Shared Reference Registers (Base Address: 01B0h)

REGISTER DESCRIPTION	REGISTER	OFFSET
Shared reference control	REFCTL	00h

Table 25. Port P1/P2 Registers (Base Address: 0200h)

REGISTER DESCRIPTION	REGISTER	OFFSET
Port P1 input	P1IN	00h
Port P1 output	P1OUT	02h
Port P1 direction	P1DIR	04h
Port P1 pullup/pulldown enable	P1REN	06h
Port P1 selection 0	P1SEL0	0Ah
Port P1 selection 1	P1SEL1	0Ch
Port P1 interrupt vector word	P1IV	0Eh
Port P1 complement selection	P1SELC	10h
Port P1 interrupt edge select	P1IES	18h
Port P1 interrupt enable	P1IE	1Ah
Port P1 interrupt flag	P1IFG	1Ch
Port P2 input	P2IN	01h
Port P2 output	P2OUT	03h
Port P2 direction	P2DIR	05h
Port P2 pullup/pulldown enable	P2REN	07h
Port P2 selection 0	P2SEL0	0Bh
Port P2 selection 1	P2SEL1	0Dh
Port P2 complement selection	P2SELC	11h
Port P2 interrupt vector word	P2IV	1Eh
Port P2 interrupt edge select	P2IES	19h
Port P2 interrupt enable	P2IE	1Bh
Port P2 interrupt flag	P2IFG	1Dh

Table 26. Port P3/P4 Registers (Base Address: 0220h)

REGISTER DESCRIPTION	REGISTER	OFFSET
Port P3 input	P3IN	00h
Port P3 output	P3OUT	02h
Port P3 direction	P3DIR	04h
Port P3 pullup/pulldown enable	P3REN	06h
Port P3 selection 0	P3SEL0	0Ah
Port P3 selection 1	P3SEL1	0Ch
Port P3 interrupt vector word	P3IV	0Eh
Port P3 complement selection	P3SELC	10h
Port P3 interrupt edge select	P3IES	18h
Port P3 interrupt enable	P3IE	1Ah
Port P3 interrupt flag	P3IFG	1Ch
Port P4 input	P4IN	01h
Port P4 output	P4OUT	03h
Port P4 direction	P4DIR	05h
Port P4 pullup/pulldown enable	P4REN	07h
Port P4 selection 0	P4SEL0	0Bh
Port P4 selection 1	P4SEL1	0Dh
Port P4 complement selection	P4SELC	11h
Port P4 interrupt vector word	P4IV	1Eh
Port P4 interrupt edge select	P4IES	19h
Port P4 interrupt enable	P4IE	1Bh
Port P4 interrupt flag	P4IFG	1Dh

Table 27. Port J Registers (Base Address: 0320h)

REGISTER DESCRIPTION	REGISTER	OFFSET
Port PJ input	PJIN	00h
Port PJ output	PJOUT	02h
Port PJ direction	PJDIR	04h
Port PJ pullup/pulldown enable	PJREN	06h
Port PJ selection 0	PJSEL0	0Ah
Port PJ selection 1	PJSEL1	0Ch

Table 28. TA0 Registers (Base Address: 0340h)

REGISTER DESCRIPTION	REGISTER	OFFSET
TA0 control	TAOCTL	00h
Capture/compare control 0	TAOCCTL0	02h
Capture/compare control 1	TAOCCTL1	04h
Capture/compare control 2	TAOCCTL2	06h
Capture/compare control 3	TAOCCTL3	08h
Capture/compare control 4	TAOCCTL4	0Ah
TA0 counter register	TAOR	10h
Capture/compare register 0	TAOCCR0	12h
Capture/compare register 1	TAOCCR1	14h
Capture/compare register 2	TAOCCR2	16h
Capture/compare register 3	TAOCCR3	18h
Capture/compare register 4	TAOCCR4	1Ah
TA0 expansion register 0	TAOEX0	20h
TA0 interrupt vector	TAOIV	2Eh

Table 29. TA1 Registers (Base Address: 0380h)

REGISTER DESCRIPTION	REGISTER	OFFSET
TA1 control	TA1CTL	00h
Capture/compare control 0	TA1CCTL0	02h
Capture/compare control 1	TA1CCTL1	04h
Capture/compare control 2	TA1CCTL2	06h
TA1 counter register	TA1R	10h
Capture/compare register 0	TA1CCR0	12h
Capture/compare register 1	TA1CCR1	14h
Capture/compare register 2	TA1CCR2	16h
TA1 expansion register 0	TA1EX0	20h
TA1 interrupt vector	TA1IV	2Eh

Table 30. TB0 Registers (Base Address: 03C0h)

REGISTER DESCRIPTION	REGISTER	OFFSET
TB0 control	TBOCTL	00h
Capture/compare control 0	TBOCCTL0	02h
Capture/compare control 1	TBOCCTL1	04h
Capture/compare control 2	TBOCCTL2	06h
TB0 register	TBOR	10h
Capture/compare register 0	TBOCCR0	12h
Capture/compare register 1	TBOCCR1	14h
Capture/compare register 2	TBOCCR2	16h
TB0 expansion register 0	TBOEX0	20h
TB0 interrupt vector	TBOIV	2Eh

Table 31. TB1 Registers (Base Address: 0400h)

REGISTER DESCRIPTION	REGISTER	OFFSET
TB1 control	TB1CTL	00h
Capture/compare control 0	TB1CCTL0	02h
Capture/compare control 1	TB1CCTL1	04h
Capture/compare control 2	TB1CCTL2	06h
TB1 register	TB1R	10h
Capture/compare register 0	TB1CCR0	12h
Capture/compare register 1	TB1CCR1	14h
Capture/compare register 2	TB1CCR2	16h
TB1 expansion register 0	TB1EX0	20h
TB1 interrupt vector	TB1IV	2Eh

Table 32. TB2 Registers (Base Address: 0440h)

REGISTER DESCRIPTION	REGISTER	OFFSET
TB2 control	TB2CTL	00h
Capture/compare control 0	TB2CCTL0	02h
Capture/compare control 1	TB2CCTL1	04h
Capture/compare control 2	TB2CCTL2	06h
TB2 register	TB2R	10h
Capture/compare register 0	TB2CCR0	12h
Capture/compare register 1	TB2CCR1	14h
Capture/compare register 2	TB2CCR2	16h
TB2 expansion register 0	TB2EX0	20h
TB2 interrupt vector	TB2IV	2Eh

Table 33. Real-Time Clock Registers (Base Address: 04A0h)

REGISTER DESCRIPTION	REGISTER	OFFSET
RTC control 0	RTCCTL0	00h
RTC control 1	RTCCTL1	01h
RTC control 2	RTCCTL2	02h
RTC control 3	RTCCTL3	03h
RTC prescaler 0 control	RTCPS0CTL	08h
RTC prescaler 1 control	RTCPS1CTL	0Ah
RTC prescaler 0	RTCPS0	0Ch
RTC prescaler 1	RTCPS1	0Dh
RTC interrupt vector word	RTCIV	0Eh
RTC seconds/counter register 1	RTCSEC/RTCNT1	10h
RTC minutes/counter register 2	RTCMIN/RTCNT2	11h
RTC hours/counter register 3	RTCHOUR/RTCNT3	12h
RTC day of week/counter register 4	RTCDOW/RTCNT4	13h
RTC days	RTCDAY	14h
RTC month	RTCMON	15h
RTC year low	RTCYEARL	16h
RTC year high	RTCYEARH	17h
RTC alarm minutes	RTCAMIN	18h
RTC alarm hours	RTCAHOUR	19h
RTC alarm day of week	RTCADOW	1Ah
RTC alarm days	RTCADAY	1Bh
Binary-to-BCD conversion register	BIN2BCD	1Ch
BCD-to-binary conversion register	BCD2BIN	1Eh

Table 34. 32-bit Hardware Multiplier Registers (Base Address: 04C0h)

REGISTER DESCRIPTION	REGISTER	OFFSET
16-bit operand 1 – multiply	MPY	00h
16-bit operand 1 – signed multiply	MPYS	02h
16-bit operand 1 – multiply accumulate	MAC	04h
16-bit operand 1 – signed multiply accumulate	MACS	06h
16-bit operand 2	OP2	08h
16 × 16 result low word	RESLO	0Ah
16 × 16 result high word	RESHI	0Ch
16 × 16 sum extension register	SUMEXT	0Eh
32-bit operand 1 – multiply low word	MPY32L	10h
32-bit operand 1 – multiply high word	MPY32H	12h
32-bit operand 1 – signed multiply low word	MPYS32L	14h
32-bit operand 1 – signed multiply high word	MPYS32H	16h
32-bit operand 1 – multiply accumulate low word	MAC32L	18h
32-bit operand 1 – multiply accumulate high word	MAC32H	1Ah
32-bit operand 1 – signed multiply accumulate low word	MACS32L	1Ch
32-bit operand 1 – signed multiply accumulate high word	MACS32H	1Eh
32-bit operand 2 – low word	OP2L	20h
32-bit operand 2 – high word	OP2H	22h
32 × 32 result 0 – least significant word	RES0	24h
32 × 32 result 1	RES1	26h
32 × 32 result 2	RES2	28h
32 × 32 result 3 – most significant word	RES3	2Ah
MPY32 control register 0	MPY32CTL0	2Ch

Table 35. DMA Registers (Base Address DMA General Control: 0500h, DMA Channel 0: 0510h, DMA Channel 1: 0520h, DMA Channel 2: 0530h)

REGISTER DESCRIPTION	REGISTER	OFFSET
DMA channel 0 control	DMA0CTL	00h
DMA channel 0 source address low	DMA0SAL	02h
DMA channel 0 source address high	DMA0SAH	04h
DMA channel 0 destination address low	DMA0DAL	06h
DMA channel 0 destination address high	DMA0DAH	08h
DMA channel 0 transfer size	DMA0SZ	0Ah
DMA channel 1 control	DMA1CTL	00h
DMA channel 1 source address low	DMA1SAL	02h
DMA channel 1 source address high	DMA1SAH	04h
DMA channel 1 destination address low	DMA1DAL	06h
DMA channel 1 destination address high	DMA1DAH	08h
DMA channel 1 transfer size	DMA1SZ	0Ah
DMA channel 2 control	DMA2CTL	00h
DMA channel 2 source address low	DMA2SAL	02h
DMA channel 2 source address high	DMA2SAH	04h
DMA channel 2 destination address low	DMA2DAL	06h
DMA channel 2 destination address high	DMA2DAH	08h
DMA channel 2 transfer size	DMA2SZ	0Ah
DMA module control 0	DMACTL0	00h
DMA module control 1	DMACTL1	02h
DMA module control 2	DMACTL2	04h
DMA module control 3	DMACTL3	06h
DMA module control 4	DMACTL4	08h
DMA interrupt vector	DMAIV	0Ah

Table 36. MPU Control Registers (Base Address: 05A0h)

REGISTER DESCRIPTION	REGISTER	OFFSET
MPU control 0	MPUCTL0	00h
MPU control 1	MPUCTL1	02h
MPU Segmentation Register	MPUSEG	04h
MPU access management	MPUSAM	06h

Table 37. eUSCI_A0 Registers (Base Address: 05C0h)

REGISTER DESCRIPTION	REGISTER	OFFSET
eUSCI_A control word 0	UCA0CTLW0	00h
eUSCI_A control word 1	UCA0CTLW1	03h
eUSCI_A baud rate 0	UCA0BR0	06h
eUSCI_A baud rate 1	UCA0BR1	07h
eUSCI_A modulation control	UCA0MCTLW	08h
eUSCI_A status	UCA0STAT	0Ah
eUSCI_A receive buffer	UCA0RXBUF	0Ch
eUSCI_A transmit buffer	UCA0TXBUF	0Eh
eUSCI_A LIN control	UCA0ABCTL	10h
eUSCI_A IrDA transmit control	UCA0IRTCTL	12h
eUSCI_A IrDA receive control	UCA0IRRCTL	13h
eUSCI_A interrupt enable	UCA0IE	1Ah
eUSCI_A interrupt flags	UCA0IFG	1Ch
eUSCI_A interrupt vector word	UCA0IV	1Eh

Table 38. eUSCI_A1 Registers (Base Address:05E0h)

REGISTER DESCRIPTION	REGISTER	OFFSET
eUSCI_A control word 0	UCA1CTLW0	00h
eUSCI_A control word 1	UCA1CTLW1	03h
eUSCI_A baud rate 0	UCA1BR0	06h
eUSCI_A baud rate 1	UCA1BR1	07h
eUSCI_A modulation control	UCA1MCTLW	08h
eUSCI_A status	UCA1STAT	0Ah
eUSCI_A receive buffer	UCA1RXBUF	0Ch
eUSCI_A transmit buffer	UCA1TXBUF	0Eh
eUSCI_A LIN control	UCA1ABCTL	10h
eUSCI_A IrDA transmit control	UCA1IRTCTL	12h
eUSCI_A IrDA receive control	UCA1IRRCTL	13h
eUSCI_A interrupt enable	UCA1IE	1Ah
eUSCI_A interrupt flags	UCA1IFG	1Ch
eUSCI_A interrupt vector word	UCA1IV	1Eh

Table 39. eUSCI_B0 Registers (Base Address: 0640h)

REGISTER DESCRIPTION	REGISTER	OFFSET
eUSCI_B control word 0	UCB0CTLW0	00h
eUSCI_B control word 1	UCB0CTLW1	02h
eUSCI_B bit rate 0	UCB0BR0	06h
eUSCI_B bit rate 1	UCB0BR1	07h
eUSCI_B status word	UCB0STATW	08h
eUSCI_B byte counter threshold	UCB0TBCNT	0Ah
eUSCI_B receive buffer	UCB0RXBUF	0Ch
eUSCI_B transmit buffer	UCB0TXBUF	0Eh
eUSCI_B I2C own address 0	UCB0I2COA0	14h
eUSCI_B I2C own address 1	UCB0I2COA1	16h
eUSCI_B I2C own address 2	UCB0I2COA2	18h
eUSCI_B I2C own address 3	UCB0I2COA3	1Ah
eUSCI_B received address	UCB0ADDRX	1Ch
eUSCI_B address mask	UCB0ADDMASK	1Eh
eUSCI I2C slave address	UCB0I2CSA	20h
eUSCI interrupt enable	UCB0IE	2Ah
eUSCI interrupt flags	UCB0IFG	2Ch
eUSCI interrupt vector word	UCB0IV	2Eh

Table 40. ADC10_B Registers (Base Address: 0700h)

REGISTER DESCRIPTION	REGISTER	OFFSET
ADC10_B Control register 0	ADC10CTL0	00h
ADC10_B Control register 1	ADC10CTL1	02h
ADC10_B Control register 2	ADC10CTL2	04h
ADC10_B Window Comparator Low Threshold	ADC10LO	06h
ADC10_B Window Comparator High Threshold	ADC10HI	08h
ADC10_B Memory Control Register 0	ADC10MCTL0	0Ah
ADC10_B Conversion Memory Register	ADC10MCTL0	12h
ADC10_B Interrupt Enable	ADC10IE	1Ah
ADC10_B Interrupt Flags	ADC10IGH	1Ch
ADC10_B Interrupt Vector Word	ADC10IV	1Eh

Table 41. Comparator_D Registers (Base Address: 08C0h)

REGISTER DESCRIPTION	REGISTER	OFFSET
Comparator_D control register 0	CDCTL0	00h
Comparator_D control register 1	CDCTL1	02h
Comparator_D control register 2	CDCTL2	04h
Comparator_D control register 3	CDCTL3	06h
Comparator_D interrupt register	CDINT	0Ch
Comparator_D interrupt vector word	CDIV	0Eh

Absolute Maximum Ratings⁽¹⁾

over operating free-air temperature range (unless otherwise noted)

Voltage applied at V_{CC} to V_{SS}	–0.3 V to 4.1 V
Voltage applied to any pin (excluding V_{CORE}) ⁽²⁾	–0.3 V to $V_{CC} + 0.3$ V
Diode current at any device pin	±2 mA
Storage temperature range, T_{stg} ^{(3) (4)(5)}	–40°C to 150°C
Maximum junction temperature, T_J	95°C

- (1) Stresses beyond those listed under "absolute maximum ratings" may cause permanent damage to the device. These are stress ratings only, and functional operation of the device at these or any other conditions beyond those indicated under "recommended operating conditions" is not implied. Exposure to absolute-maximum-rated conditions for extended periods may affect device reliability.
- (2) All voltages referenced to V_{SS} . V_{CORE} is for internal device usage only. No external DC loading or voltage should be applied.
- (3) Higher temperature may be applied during board soldering according to the current JEDEC J-STD-020 specification with peak reflow temperatures not higher than classified on the device label on the shipping boxes or reels.
- (4) FRAM memory retention loss increases with higher temperatures such as those experienced during board soldering. Programming of devices with user application code can only be performed post reflow. Factory programmed information such as calibration values are designed to withstand the temperatures normally reached in the current JEDEC J-STD-020 specification.
- (5) In general, hand soldering is not recommended. However, if hand soldering is required for application prototyping, peak temperature must not exceed 250°C for 5 minutes. In addition, user application code should not be programmed prior to hand soldering.

Recommended Operating Conditions

		MIN	NOM	MAX	UNIT	
V_{CC}	Supply voltage during program execution and FRAM programming ($AV_{CC} = DV_{CC}$) ⁽¹⁾	2.0		3.6	V	
V_{SS}	Supply voltage ($AV_{SS} = DV_{SS}$)		0		V	
T_A	Operating free-air temperature	–40		85	°C	
T_J	Operating junction temperature	–40		85	°C	
CVCORE	Required capacitor at V_{CORE}		470		nF	
CVCC/ CVCORE	Capacitor ratio of V_{CC} to V_{CORE}		10			
f_{SYSTEM}	Processor frequency (maximum MCLK frequency) ⁽²⁾	No FRAM wait states $2.0\text{ V} \leq V_{CC} \leq 3.6\text{ V}$		0	8.0	MHz
		With FRAM wait states NACCESS = {1}, NPRECHG = {2} $2.0\text{ V} \leq V_{CC} \leq 3.6\text{ V}$		0	24.0	

- (1) It is recommended to power AV_{CC} and DV_{CC} from the same source. A maximum difference of 0.3 V between AV_{CC} and DV_{CC} can be tolerated during power up and operation.
- (2) Modules may have a different maximum input clock specification. Refer to the specification of the respective module in this data sheet.

INPUT/OUTPUT SCHEMATICS

Port P1, P1.0 to P1.2, Input/Output With Schmitt Trigger

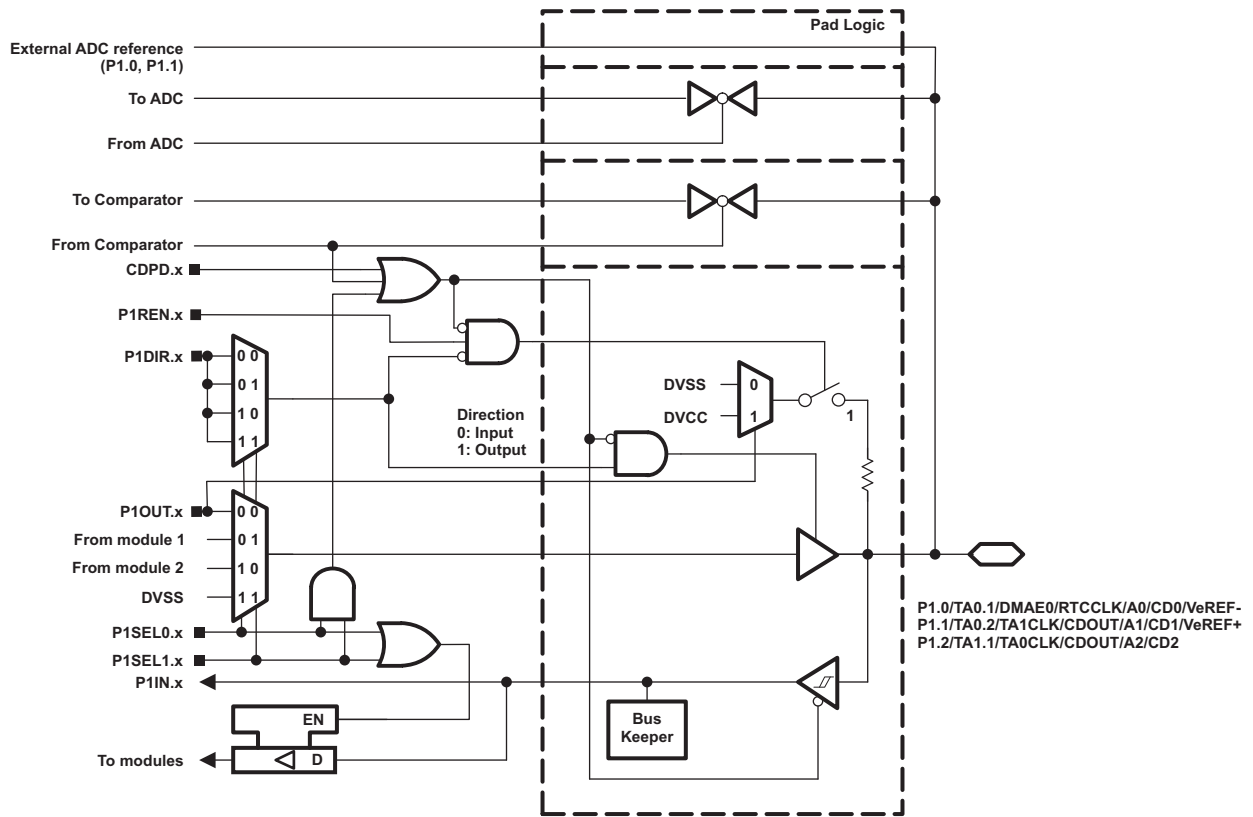

PRODUCT PREVIEW

Table 42. Port P1 (P1.0 to P1.2) Pin Functions

PIN NAME (P1.x)	x	FUNCTION	CONTROL BITS/SIGNALS		
			P1DIR.x	P1SEL1.x	P1SEL0.x
P1.0/TA0.1/DMAE0/RTCCLK/A0/CD0/VeREF-	0	P1.0 (I/O)	I: 0; O: 1	0	0
		TA0.CCI1A	0	0	1
		TA0.1	1		
		DMAE0	0	1	0
		RTCCLK	1		
		A0 ⁽¹⁾⁽²⁾ CD0 ⁽¹⁾⁽³⁾ VeREF- ⁽¹⁾⁽²⁾	X	1	1
P1.1/TA0.2/TA1CLK/CDOUT/A1/CD1/VeREF+	1	P1.1 (I/O)	I: 0; O: 1	0	0
		TA0.CCI2A	0	0	1
		TA0.2	1		
		TA1CLK	0	1	0
		CDOUT	1		
		A1 ⁽¹⁾⁽²⁾ CD1 ⁽¹⁾⁽³⁾ VeREF+ ⁽¹⁾⁽²⁾	X	1	1
P1.2/TA1.1/TA0CLK/CDOUT/A2/CD2	2	P1.2 (I/O)	I: 0; O: 1	0	0
		TA1.CCI1A	0	0	1
		TA1.1	1		
		TA0CLK	0	1	0
		CDOUT	1		
		A2 ⁽¹⁾⁽²⁾ CD2 ⁽¹⁾⁽³⁾	X	1	1

- (1) Setting P1SEL1.x and P1SEL0.x will disable the output driver as well as the input Schmitt trigger to prevent parasitic cross currents when applying analog signals.
- (2) Not available on all devices and package types.
- (3) Setting the CDPD.x bit of the comparator will disable the output driver as well as the input Schmitt trigger to prevent parasitic cross currents when applying analog signals. Selecting the CDx input pin to the comparator multiplexer with the CDx bits automatically disables output driver and input buffer for that pin, regardless of the state of the associated CDPD.x bit.

Port P1, P1.3 to P1.5, Input/Output With Schmitt Trigger

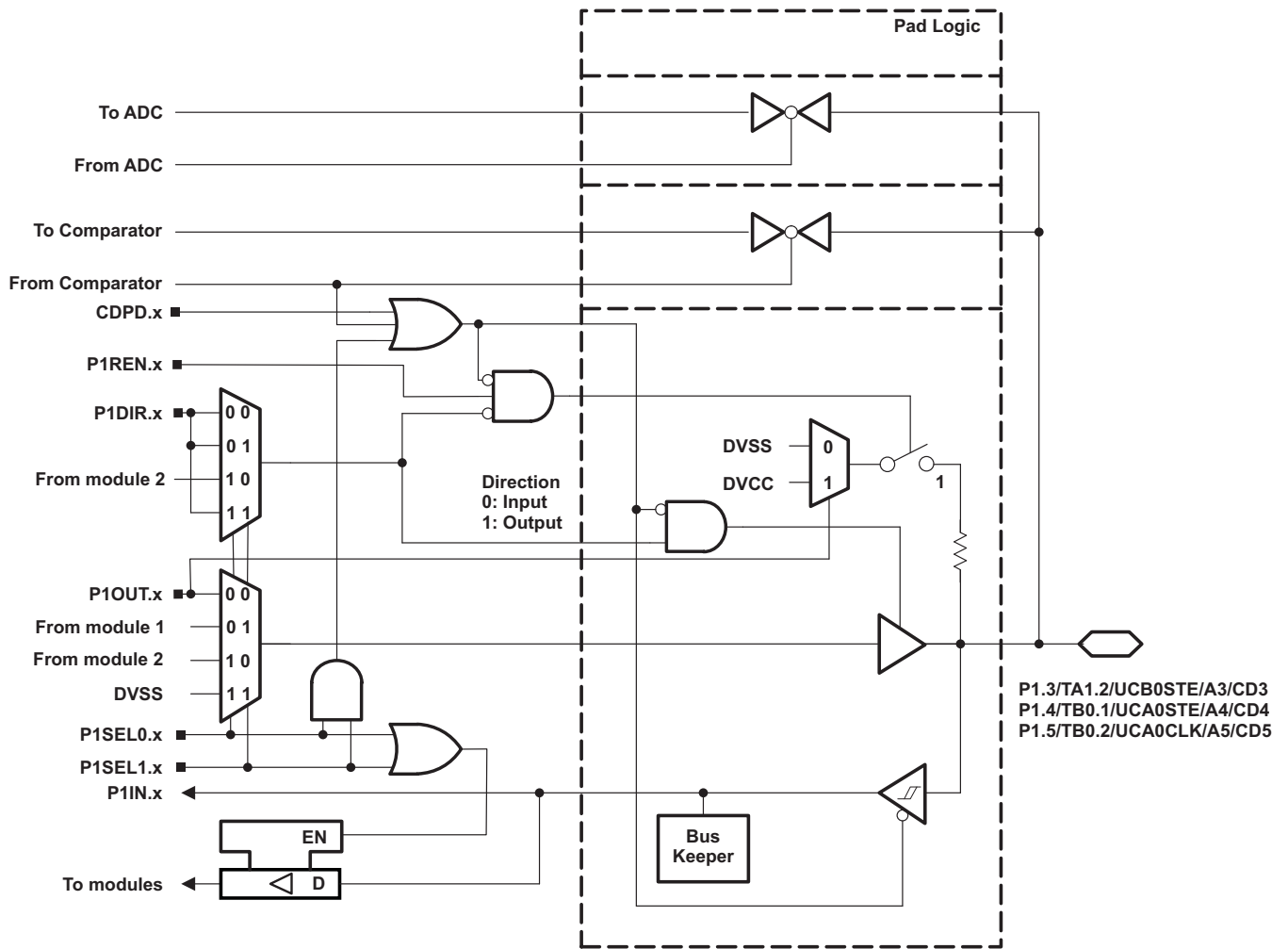

PRODUCT PREVIEW

Table 43. Port P1 (P1.3 to P1.5) Pin Functions

PIN NAME (P1.x)	x	FUNCTION	CONTROL BITS/SIGNALS		
			P1DIR.x	P1SEL1.x	P1SEL0.x
P1.3/TA1.2/UCB0STE/A3/CD3	3	P1.3 (I/O)	I: 0; O: 1	0	0
		TA1.CCI2A	0	0	1
		TA1.2	1		
		UCB0STE	X ⁽¹⁾	1	0
		A3 ⁽²⁾⁽³⁾ CD3 ⁽²⁾⁽⁴⁾	X	1	1
P1.4/TB0.1/UCA0STE/A4/CD4	4	P1.4 (I/O)	I: 0; O: 1	0	0
		TB0.CCI1A	0	0	1
		TB0.1	1		
		UCA0STE	X ⁽⁵⁾	1	0
		A4 ⁽²⁾⁽³⁾ CD4 ⁽²⁾⁽⁴⁾	X	1	1
P1.5/TB0.2/UCA0CLK/A5/CD5	5	P1.5(I/O)	I: 0; O: 1	0	0
		TB0.CCI2A	0	0	1
		TB0.2	1		
		UCA0CLK	X ⁽⁵⁾	1	0
		A5 ⁽²⁾⁽³⁾ CD5 ⁽²⁾⁽⁴⁾	X	1	1

- (1) Direction controlled by eUSCI_B0 module.
- (2) Setting P1SEL1.x and P1SEL0.x will disable the output driver as well as the input Schmitt trigger to prevent parasitic cross currents when applying analog signals.
- (3) Not available on all devices and package types.
- (4) Setting the CDPD.x bit of the comparator will disable the output driver as well as the input Schmitt trigger to prevent parasitic cross currents when applying analog signals. Selecting the CDx input pin to the comparator multiplexer with the CDx bits automatically disables output driver and input buffer for that pin, regardless of the state of the associated CDPD.x bit
- (5) Direction controlled by eUSCI_A0 module.

Port P1, P1.6 to P1.7, Input/Output With Schmitt Trigger

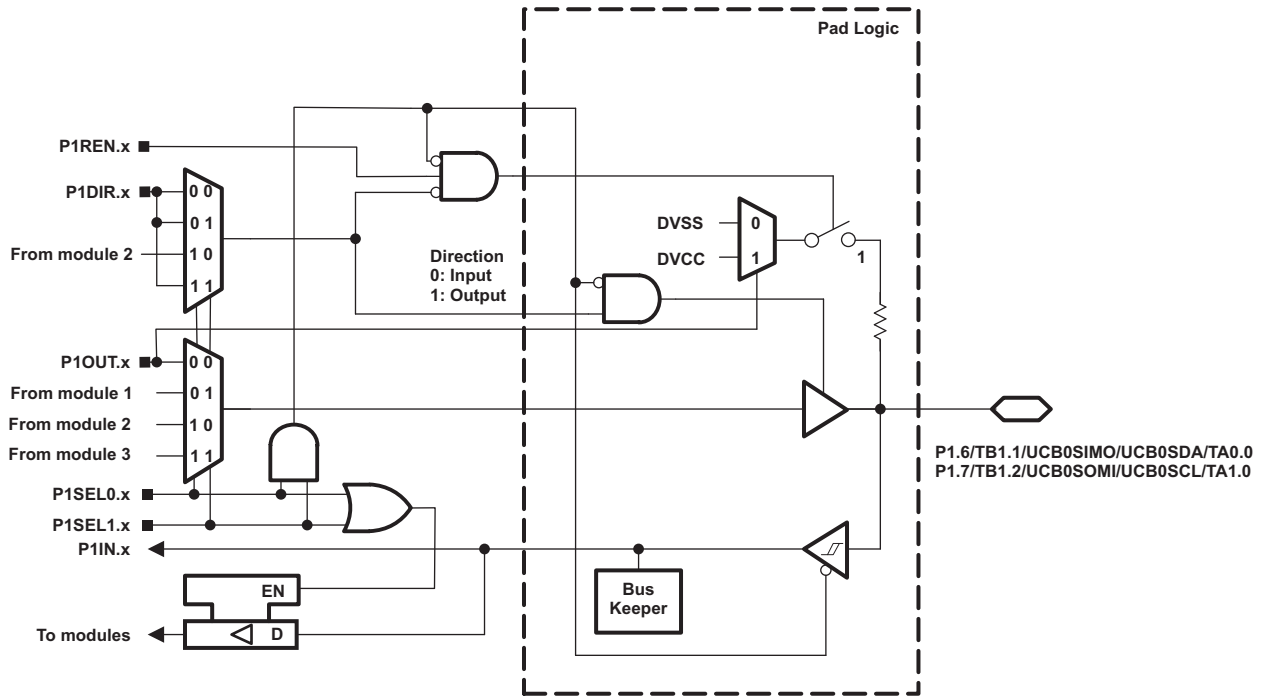

Table 44. Port P1 (P1.6 to P1.7) Pin Functions

PIN NAME (P1.x)	x	FUNCTION	CONTROL BITS/SIGNALS		
			P1DIR.x	P1SEL1.x	P1SEL0.x
P1.6/TB1.1/UCB0SIMO/UCB0SDA/TA0.0	6	P1.6 (I/O)	I: 0; O: 1	0	0
		TB1.CCI1A ⁽¹⁾	0	0	1
		TB1.1 ⁽¹⁾	1		
		UCB0SIMO/UCB0SDA	X ⁽²⁾	1	0
		TA0.CCI0A	0	1	1
		TA0.0	1		
P1.7/TB1.2/UCB0SOMI/UCB0SCL/TA1.0	7	P1.7 (I/O)	I: 0; O: 1	0	0
		TB1.CCI2A ⁽¹⁾	0	0	1
		TB1.2 ⁽¹⁾	1		
		UCB0SOMI/UCB0SCL	X ⁽³⁾	1	0
		TA1.CCI0A	0	1	1
		TA1.0	1		

(1) Not available on all devices and package types.
 (2) Direction controlled by eUSCI_B0 module.
 (3) Direction controlled by eUSCI_A0 module.

Port P2, P2.0 to P2.2, Input/Output With Schmitt Trigger

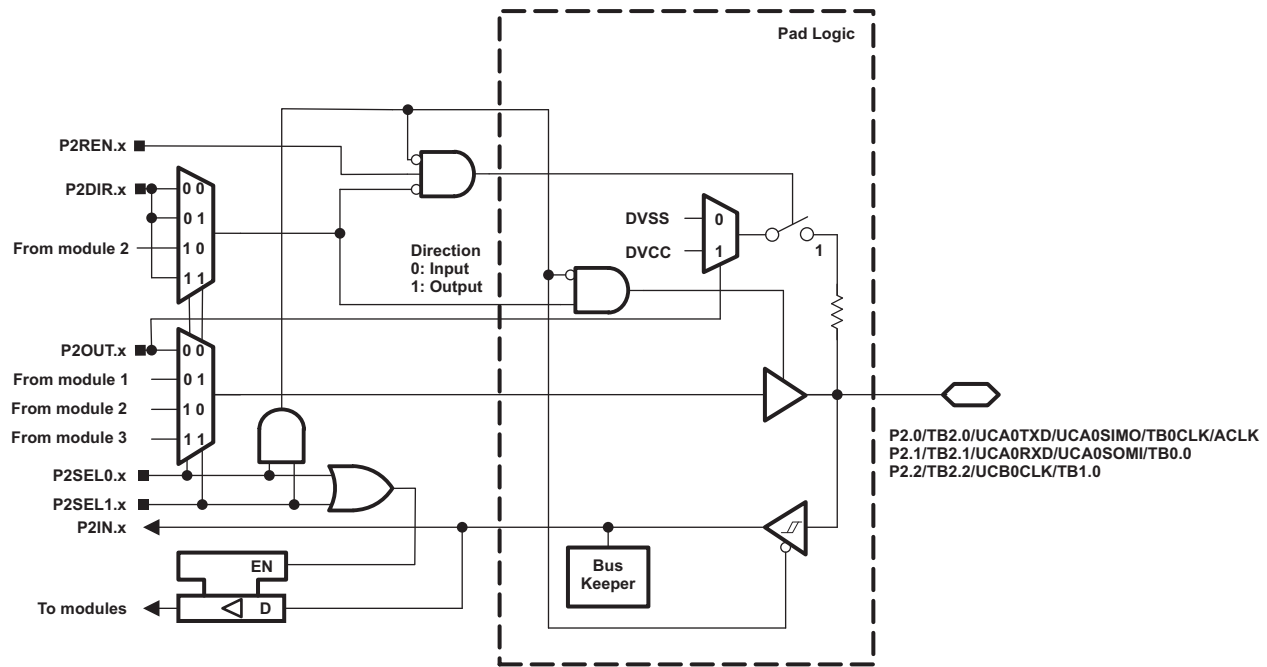
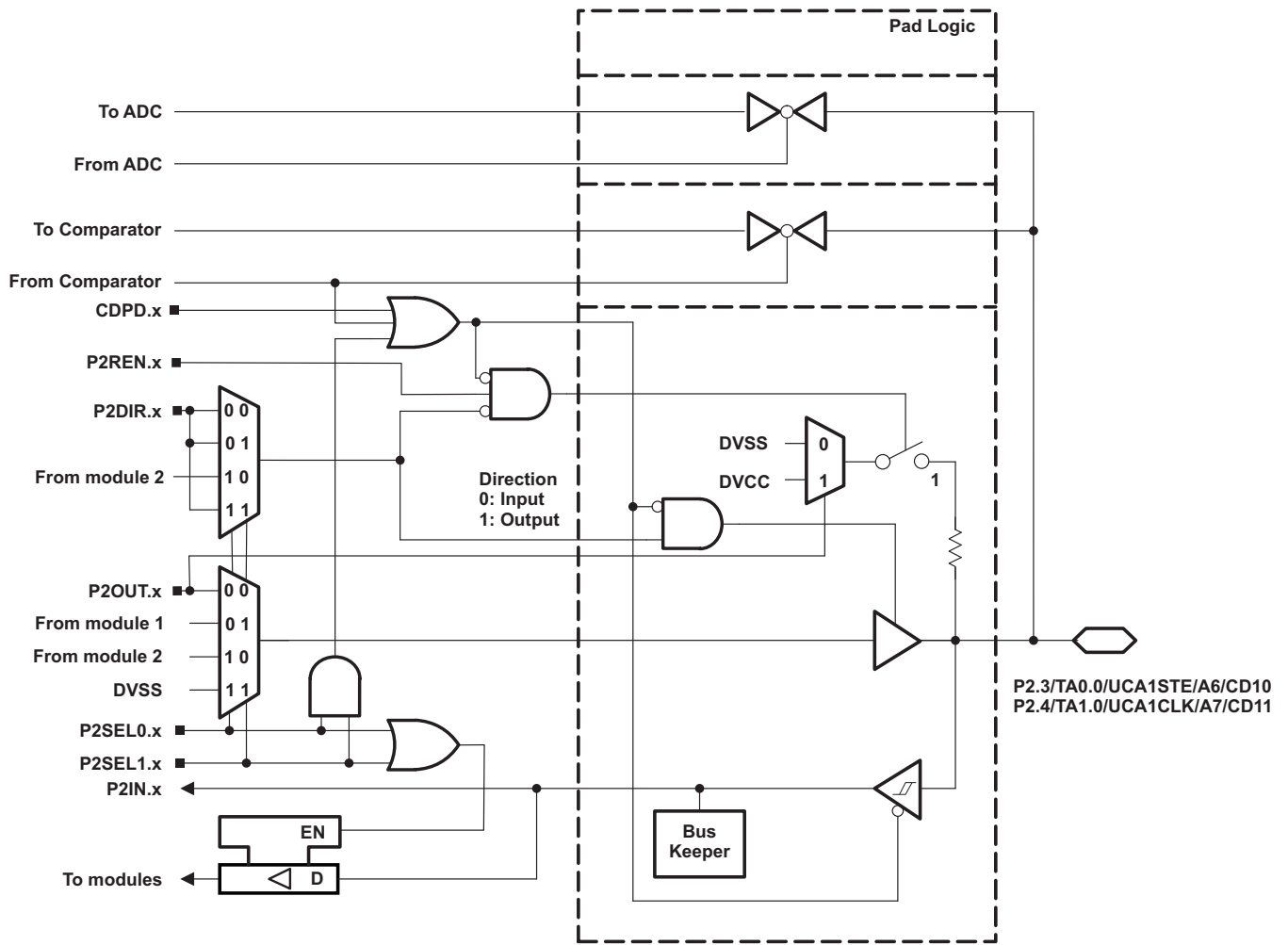

Table 45. Port P2 (P2.0 to P2.2) Pin Functions

PIN NAME (P2.x)	x	FUNCTION	CONTROL BITS/SIGNALS		
			P2DIR.x	P2SEL1.x	P2SEL0.x
P2.0/TB2.0/UCA0TXD/UCA0SIMO/TB0CLK/ACLK	0	P2.0 (I/O)	I: 0; O: 1	0	0
		TB2.CCI0A ⁽¹⁾	0	0	1
		TB2.0 ⁽¹⁾	1		
		UCA0TXD/UCA0SIMO	X ⁽²⁾	1	0
		TB0CLK	0	1	1
		ACLK	1		
P2.1/TB2.1/UCA0RXD/UCA0SOMI/TB0.0	1	P2.1 (I/O)	I: 0; O: 1	0	0
		TB2.CCI1A ⁽¹⁾	0	0	1
		TB2.1 ⁽¹⁾	1		
		UCA0RXD/UCA0SOMI	X ⁽²⁾	1	0
		TB0.CCI0A	0	1	1
		TB0.0	1		
P2.2/TB2.2/UCB0CLK/TB1.0	2	P2.2 (I/O)	I: 0; O: 1	0	0
		TB2.CCI2A ⁽¹⁾	0	0	1
		TB2.2 ⁽¹⁾	1		
		UCB0CLK	X ⁽³⁾	1	0
		TB1.CCI0A ⁽¹⁾	0	1	1
		TB1.0 ⁽¹⁾	1		

(1) Not available on all devices and package types.
 (2) Direction controlled by eUSCI_A0 module.
 (3) Direction controlled by eUSCI_B0 module.

Port P2, P2.3 to P2.4, Input/Output With Schmitt Trigger



PRODUCT PREVIEW

Table 46. Port P2 (P2.3 to P2.4) Pin Functions

PIN NAME (P2.x)	x	FUNCTION	CONTROL BITS/SIGNALS		
			P2DIR.x	P2SEL1.x	P2SEL0.x
P2.3/TA0.0/UCA1STE/A6/CD10	3	P2.3 (I/O)	I: 0; O: 1	0	0
		TA0.CCI0B	0	0	1
		TA0.0	1		
		UCA1STE	X ⁽¹⁾	1	0
		A6 ⁽²⁾⁽³⁾ CD10 ⁽²⁾⁽⁴⁾	X	1	1
P2.4/TA1.0/UCA1CLK/A7/CD11	4	P2.4 (I/O)	I: 0; O: 1	0	0
		TA1.CCI0B	0	0	1
		TA1.0	1		
		UCA1CLK	X ⁽¹⁾	1	0
		A7 ⁽²⁾⁽³⁾ CD11 ⁽²⁾⁽⁴⁾	X	1	1

- (1) Direction controlled by eUSCI_A1 module.
- (2) Setting P2SEL1.x and P2SEL0.x will disable the output driver as well as the input Schmitt trigger to prevent parasitic cross currents when applying analog signals.
- (3) Not available on all devices and package types.
- (4) Setting the CDPD.x bit of the comparator will disable the output driver as well as the input Schmitt trigger to prevent parasitic cross currents when applying analog signals. Selecting the CDx input pin to the comparator multiplexer with the CDx bits automatically disables output driver and input buffer for that pin, regardless of the state of the associated CDPD.x bit.

Port P2, P2.5 to P2.6, Input/Output With Schmitt Trigger

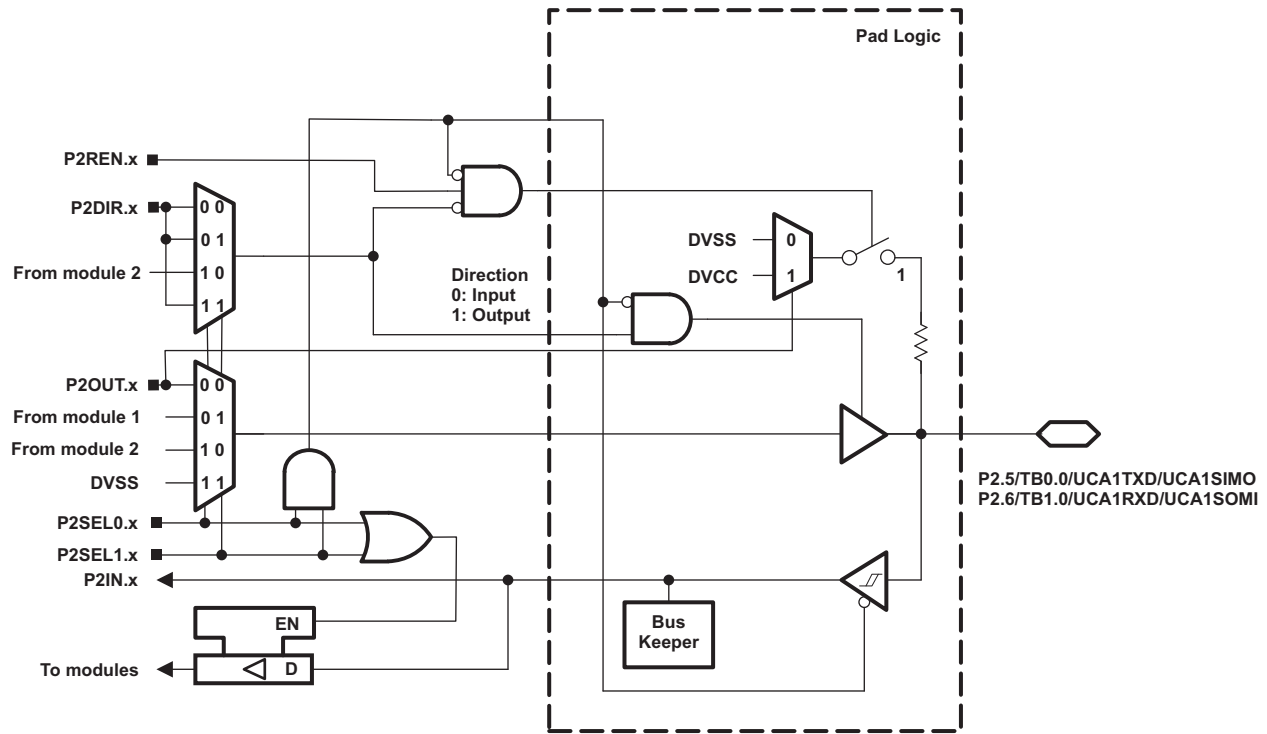

Table 47. Port P2 (P2.5 to P2.6) Pin Functions

PIN NAME (P2.x)	x	FUNCTION	CONTROL BITS/SIGNALS		
			P2DIR.x	P2SEL1.x	P2SEL0.x
P2.5/TB0.0/UCA1TXD/UCA1SIMO	5	P2.5(I/O) ⁽¹⁾	I: 0; O: 1	0	0
		TB0.CCI0B ⁽¹⁾	0	0	1
		TB0.0 ⁽¹⁾	1		
		UCA1TXD/UCA1SIMO ⁽¹⁾	X ⁽²⁾	1	0
P2.6/TB1.0/UCA1RXD/UCA1SOMI	6	P2.6(I/O) ⁽¹⁾	I: 0; O: 1	0	0
		TB1.CCI0B ⁽¹⁾	0	0	1
		TB1.0 ⁽¹⁾	1		
		UCA1RXD/UCA1SOMI ⁽¹⁾	X ⁽²⁾	1	0

(1) Not available on all devices and package types.

(2) Direction controlled by eUSCI_A1 module.

Port P2, P2.7, Input/Output With Schmitt Trigger

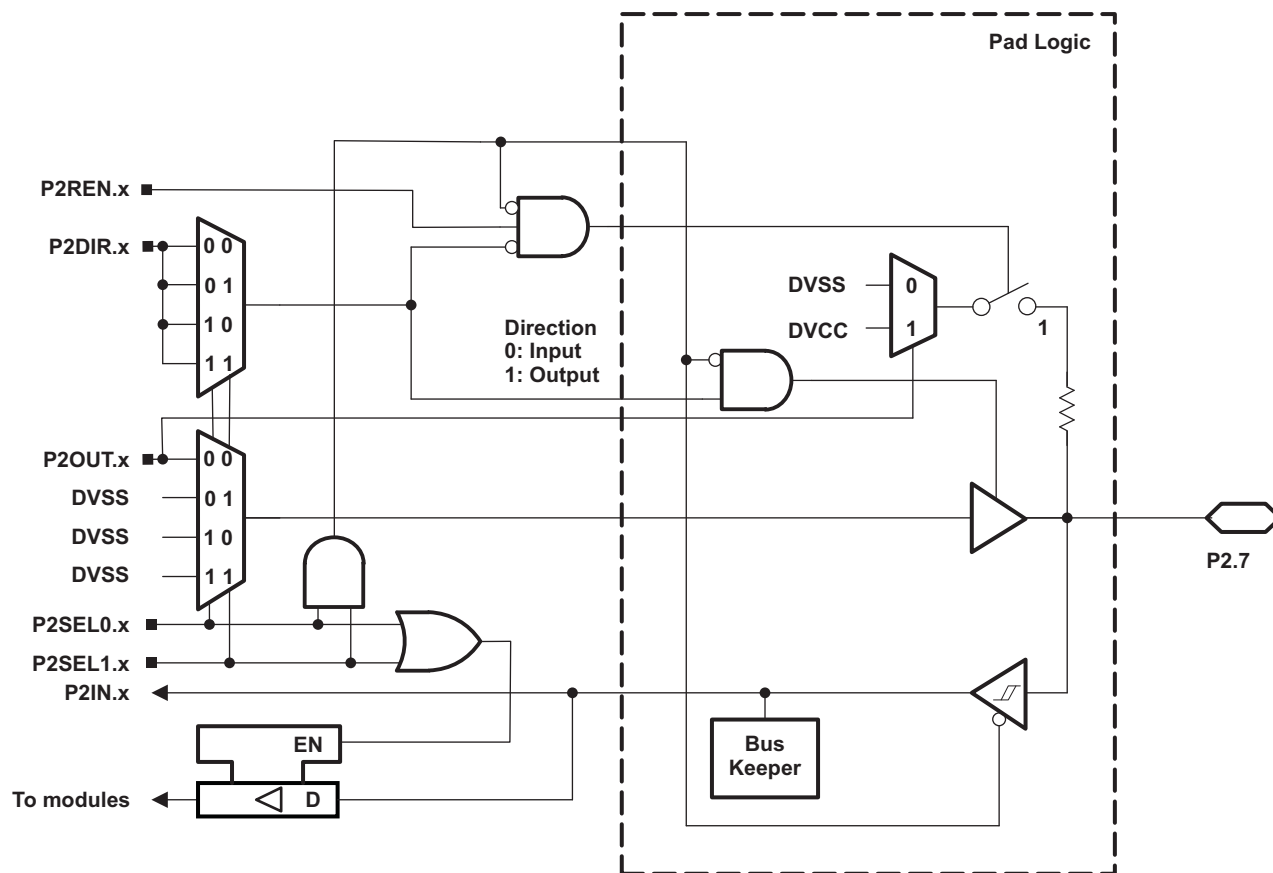

Table 48. Port P2 (P2.7) Pin Functions

PIN NAME (P2.x)	x	FUNCTION	CONTROL BITS/SIGNALS		
			P2DIR.x	P2SEL1.x	P2SEL0.x
P2.7	7	P2.7(I/O) ⁽¹⁾	I: 0; O: 1	0	0

(1) Not available on all devices and package types.

PRODUCT PREVIEW

Port P3, P3.0 to P3.3, Input/Output With Schmitt Trigger

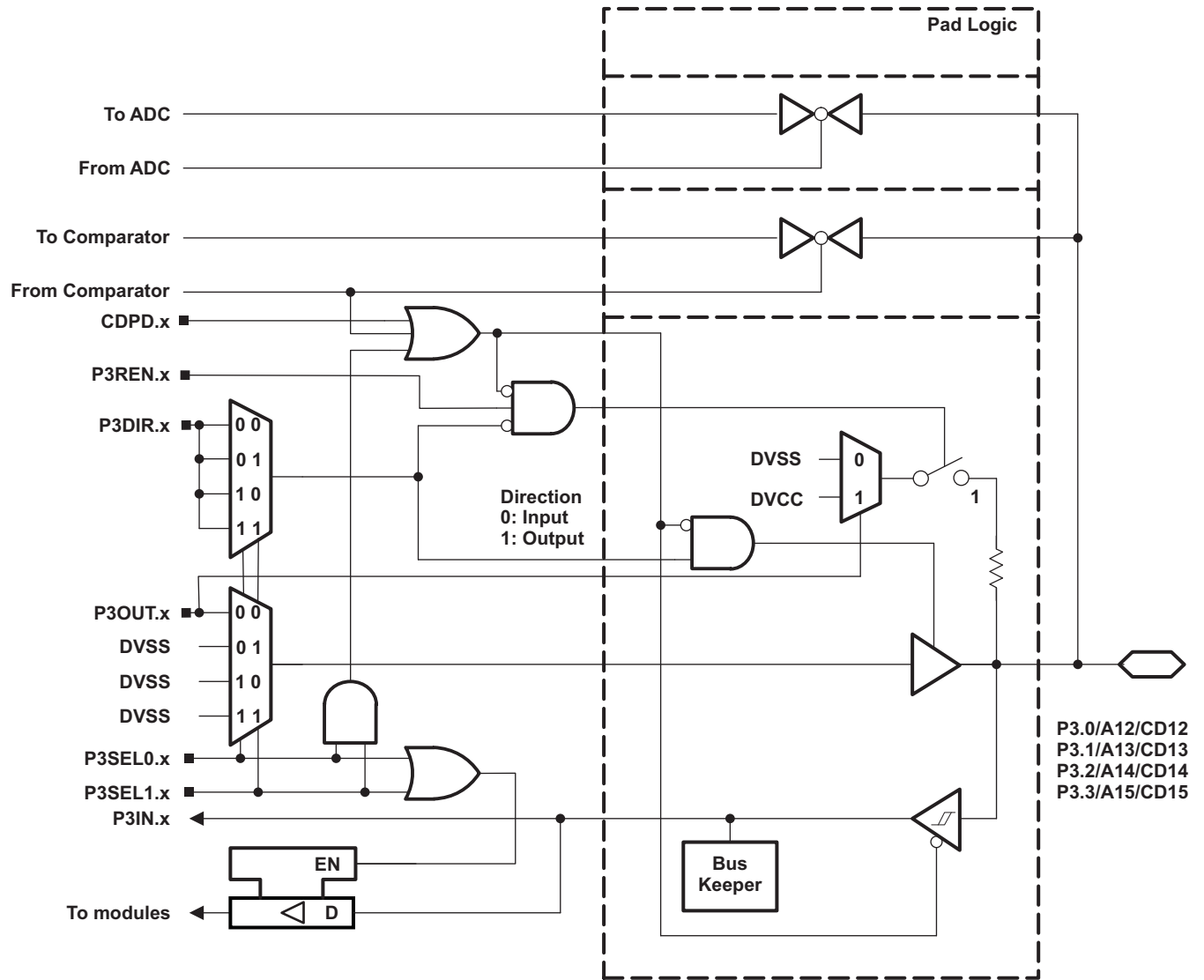

PRODUCT PREVIEW

Table 49. Port P3 (P3.0 to P3.3) Pin Functions

PIN NAME (P3.x)	x	FUNCTION	CONTROL BITS/SIGNALS		
			P3DIR.x	P3SEL1.x	P3SEL0.x
P3.0/A12/CD12	0	P3.0 (I/O)	I: 0; O: 1	0	0
		A12 ⁽¹⁾⁽²⁾ CD12 ⁽¹⁾⁽³⁾	X	1	1
P3.1/A13/CD13	1	P3.1 (I/O)	I: 0; O: 1	0	0
		A13 ⁽¹⁾⁽²⁾ CD13 ⁽¹⁾⁽³⁾	X	1	1
P3.2/A14/CD14	2	P3.2 (I/O)	I: 0; O: 1	0	0
		A14 ⁽¹⁾⁽²⁾ CD14 ⁽¹⁾⁽³⁾	X	1	1
P3.3/A15/CD15	3	P3.3 (I/O)	I: 0; O: 1	0	0
		A15 ⁽¹⁾⁽²⁾ CD15 ⁽¹⁾⁽³⁾	X	1	1

- (1) Setting P1SEL1.x and P1SEL0.x will disable the output driver as well as the input Schmitt trigger to prevent parasitic cross currents when applying analog signals.
- (2) Not available on all devices and package types.
- (3) Setting the CDPD.x bit of the comparator will disable the output driver as well as the input Schmitt trigger to prevent parasitic cross currents when applying analog signals. Selecting the CDx input pin to the comparator multiplexer with the CDx bits automatically disables output driver and input buffer for that pin, regardless of the state of the associated CDPD.x bit.

Port P3, P3.4 to P3.6, Input/Output With Schmitt Trigger

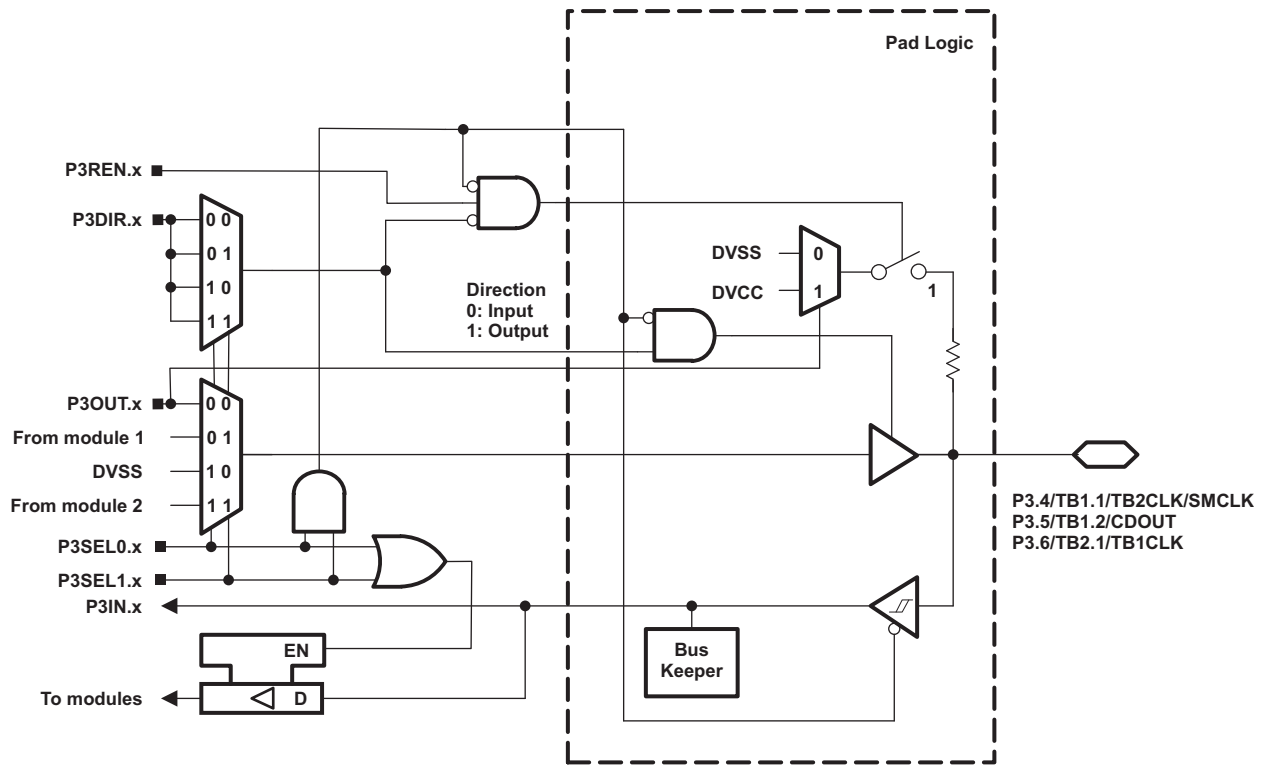

Table 50. Port P3 (P3.4 to P3.6) Pin Functions

PIN NAME (P3.x)	x	FUNCTION	CONTROL BITS/SIGNALS		
			P3DIR.x	P3SEL1.x	P3SEL0.x
P3.4/TB1.1/TB2CLK/SMCLK	4	P3.4 (I/O) ⁽¹⁾	I: 0; O: 1	0	0
		TB1.CCI1B ⁽¹⁾	0	0	1
		TB1.1 ⁽¹⁾	1	0	1
		TB2CLK ⁽¹⁾	0	1	1
P3.5/TB1.2/CDOOUT	5	P3.5 (I/O) ⁽¹⁾	I: 0; O: 1	0	0
		TB1.CCI2B ⁽¹⁾	0	0	1
		TB1.2 ⁽¹⁾	1	0	1
P3.6/TB2.1/TB1CLK	6	P3.6 (I/O) ⁽¹⁾	I: 0; O: 1	0	0
		TB2.CCI1B ⁽¹⁾	0	0	1
		TB2.1 ⁽¹⁾	1	0	1
		TB1CLK ⁽¹⁾	0	1	1

(1) Not available on all devices and package types.

Port P3, P3.7, Input/Output With Schmitt Trigger

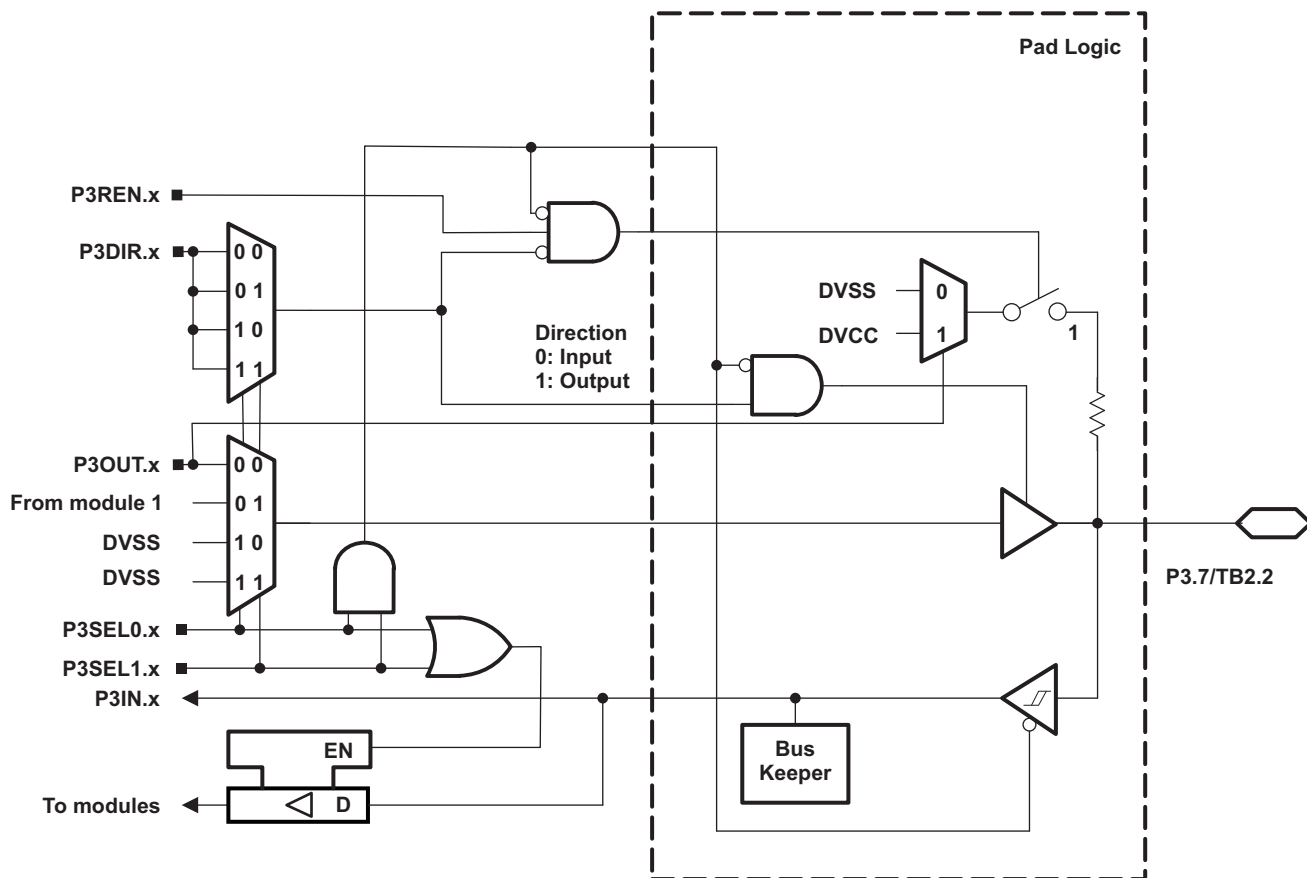

Table 51. Port P3 (P3.7) Pin Functions

PIN NAME (P3.x)	x	FUNCTION	CONTROL BITS/SIGNALS		
			P3DIR.x	P3SEL1.x	P3SEL0.x
P3.7/TB2.2	7	P3.7 (I/O) ⁽¹⁾	I: 0; O: 1	0	0
		TB2.CCI2B ⁽¹⁾	0	0	1
		TB2.2 ⁽¹⁾	1		

(1) Not available on all devices and package types.

PRODUCT PREVIEW

Port P4, P4.0, Input/Output With Schmitt Trigger

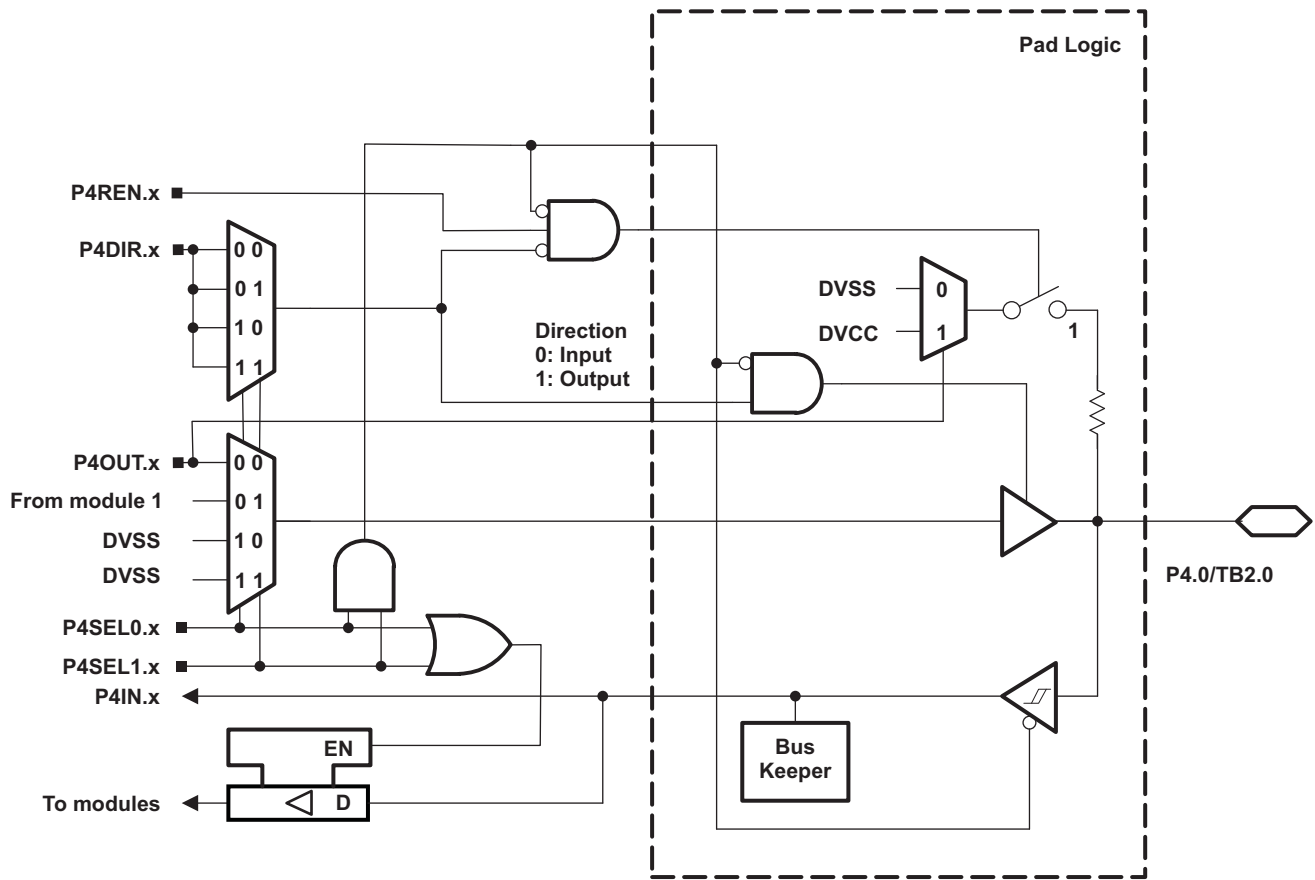

Table 52. Port P4 (P4.0) Pin Functions

PIN NAME (P4.x)	x	FUNCTION	CONTROL BITS/SIGNALS		
			P4DIR.x	P4SEL1.x	P4SEL0.x
P4.0/TB2.0	0	P4.0 (I/O) ⁽¹⁾	I: 0; O: 1	0	0
		TB2.CCI0B ⁽¹⁾	0	0	1
		TB2.0 ⁽¹⁾	1		

(1) Not available on all devices and package types.

Port P4, P4.1, Input/Output With Schmitt Trigger

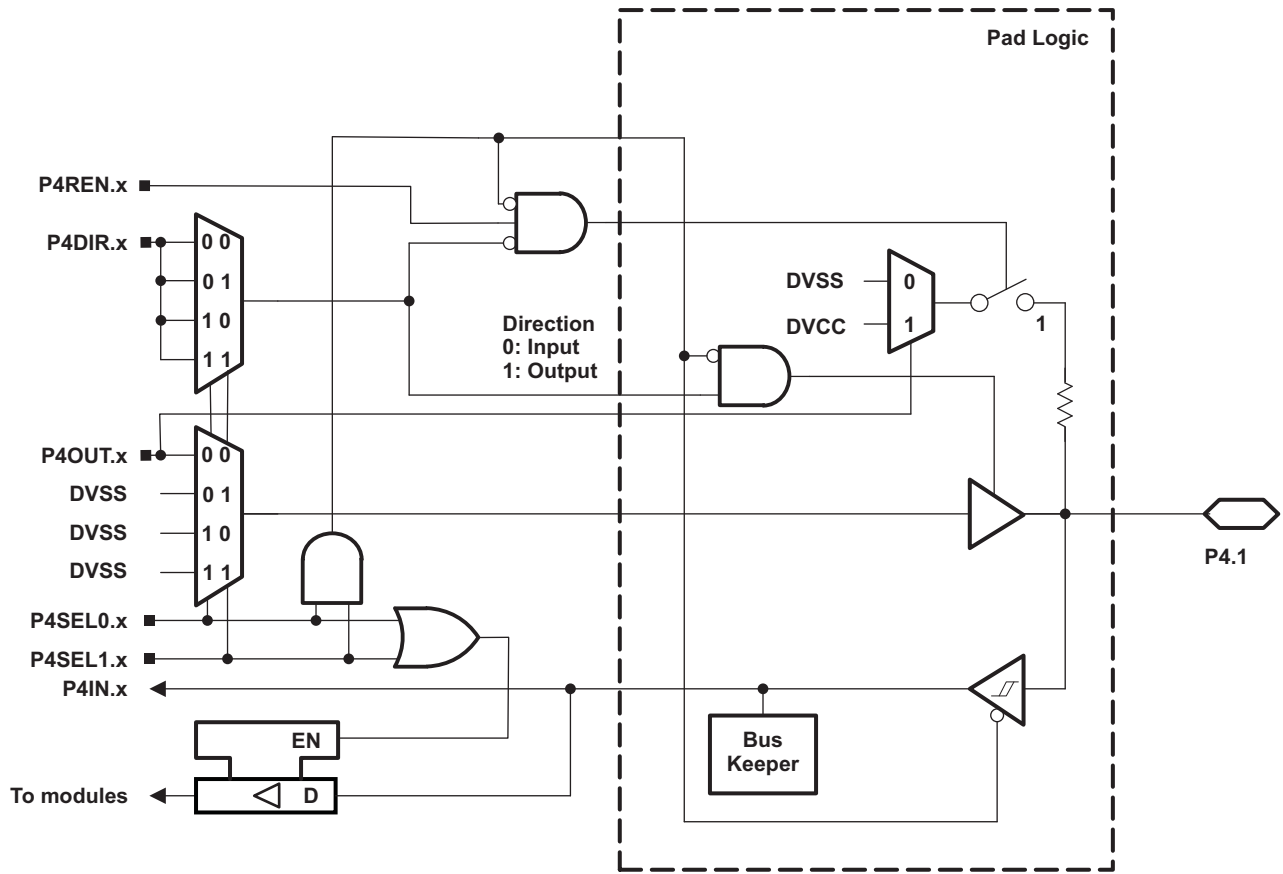

Table 53. Port P4 (P4.1) Pin Functions

PIN NAME (P4.x)	x	FUNCTION	CONTROL BITS/SIGNALS		
			P4DIR.x	P4SEL1.x	P4SEL0.x
P4.1	1	P4.1 (I/O) ⁽¹⁾	I: 0; O: 1	0	0

(1) Not available on all devices and package types.

PRODUCT PREVIEW

Port PJ, PJ.4 and PJ.5 Input/Output With Schmitt Trigger

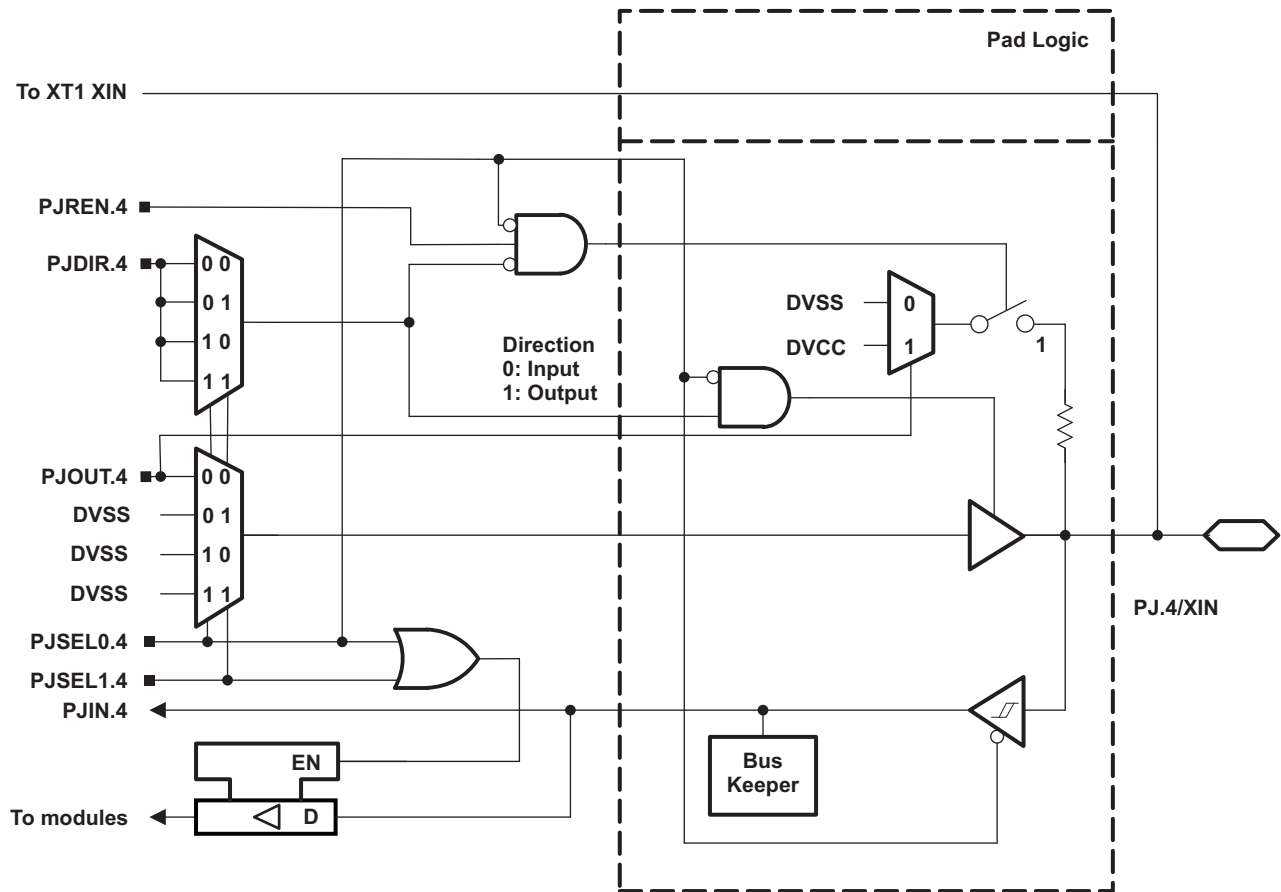

PRODUCT PREVIEW

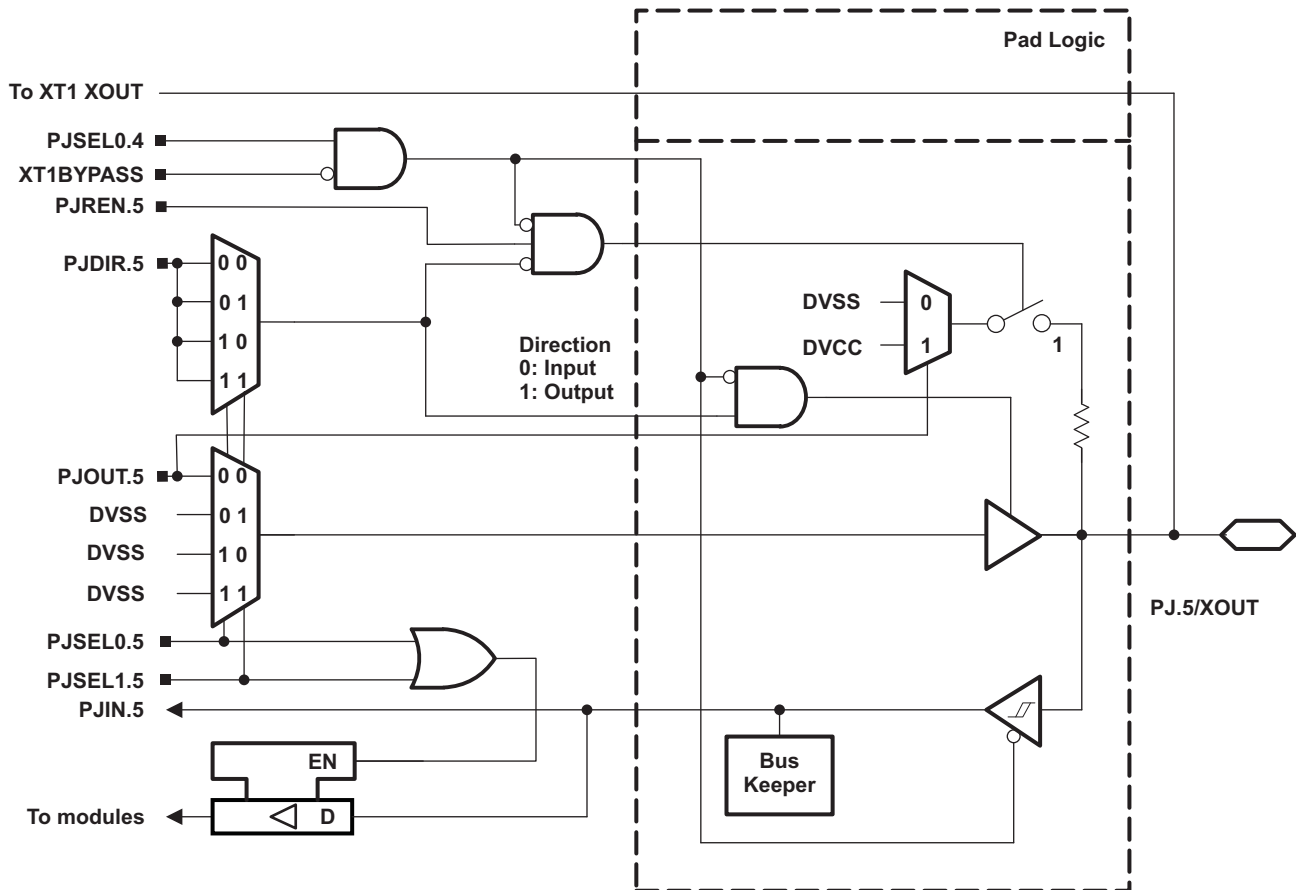

Table 54. Port PJ (PJ.4 and PJ.5) Pin Functions

PIN NAME (P7.x)	x	FUNCTION	CONTROL BITS/SIGNALS ⁽¹⁾					
			PJDIR.x	PJSEL1.5	PJSEL0.5	PJSEL1.4	PJSEL0.4	XT1BYPASS
PJ.4/XIN	4	PJ.4 (I/O)	I: 0; O: 1	X	X	0	0	X
		XIN crystal mode ⁽²⁾	X	X	X	0	1	0
		XIN bypass mode ⁽²⁾	X	X	X	0	1	1
PJ.5/XOUT	5	PJ.5 (I/O)	I: 0; O: 1	0	0	0	0	X
		XOUT crystal mode ⁽³⁾	X	X	X	0	1	0
		PJ.5 (I/O) ⁽⁴⁾	I: 0; O: 1	X	X	0	1	1

- (1) X = Don't care
- (2) Setting PJSEL1.4 = 0 and PJSEL0.4 = 1 causes the general-purpose I/O to be disabled. When XT1BYPASS = 0, PJ.4 and PJ.5 are configured for crystal operation and PJSEL1.5 and PJSEL0.5 are do not care. When XT1BYPASS = 1, PJ.4 is configured for bypass operation and PJ.5 is configured as general-purpose I/O.
- (3) Setting PJSEL1.4 = 0 and PJSEL0.4 = 1 causes the general-purpose I/O to be disabled. When XT1BYPASS = 0, PJ.4 and PJ.5 are configured for crystal operation and PJSEL1.5 and PJSEL0.5 are do not care. When XT1BYPASS = 1, PJ.4 is configured for bypass operation and PJ.5 is configured as general-purpose I/O.
- (4) When PJ.4 is configured in bypass mode, PJ.5 is configured as general-purpose I/O.

PRODUCT PREVIEW

Port J, J.0 to J.3 JTAG pins TDO, TMS, TCK, TDI/TCLK, Input/Output With Schmitt Trigger or Output

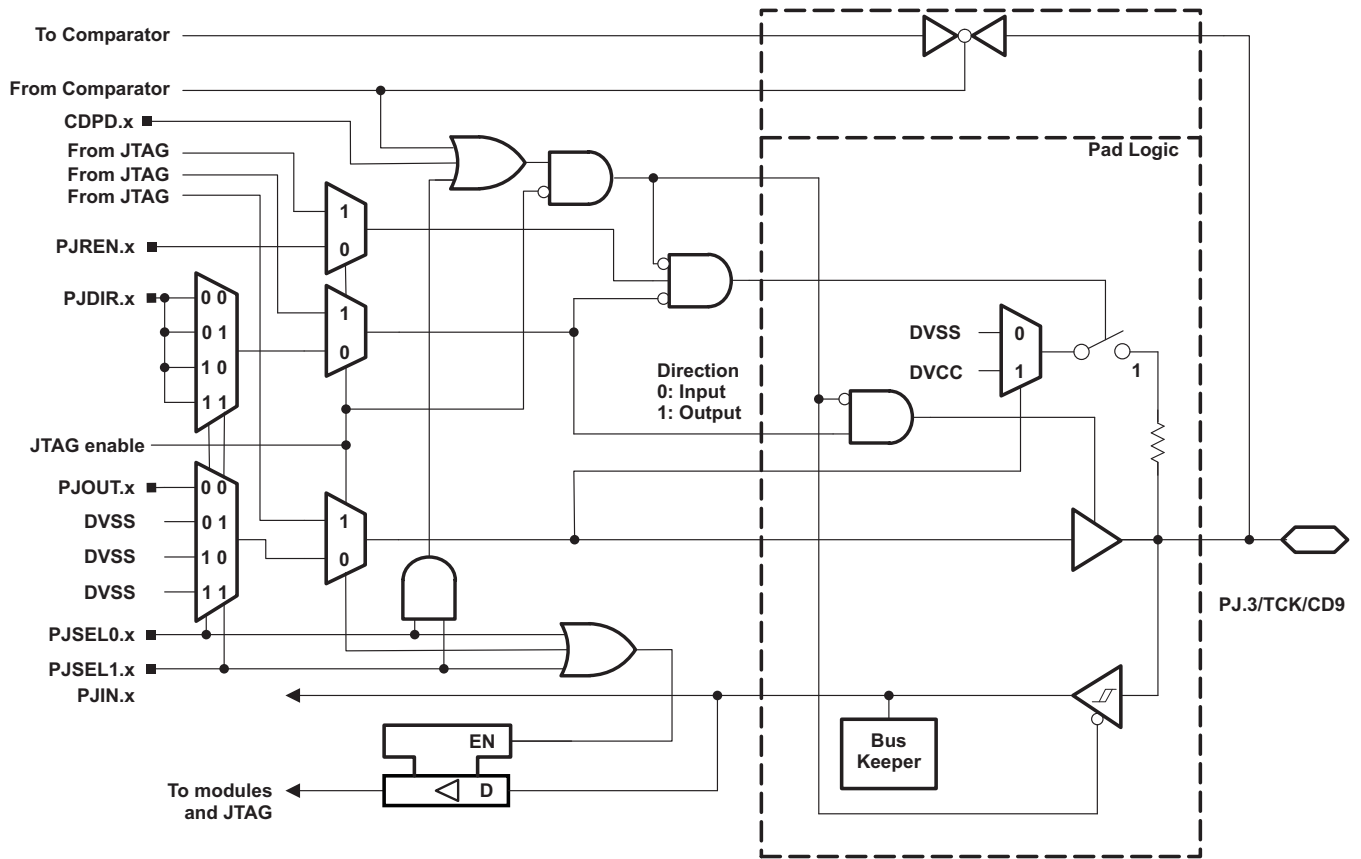
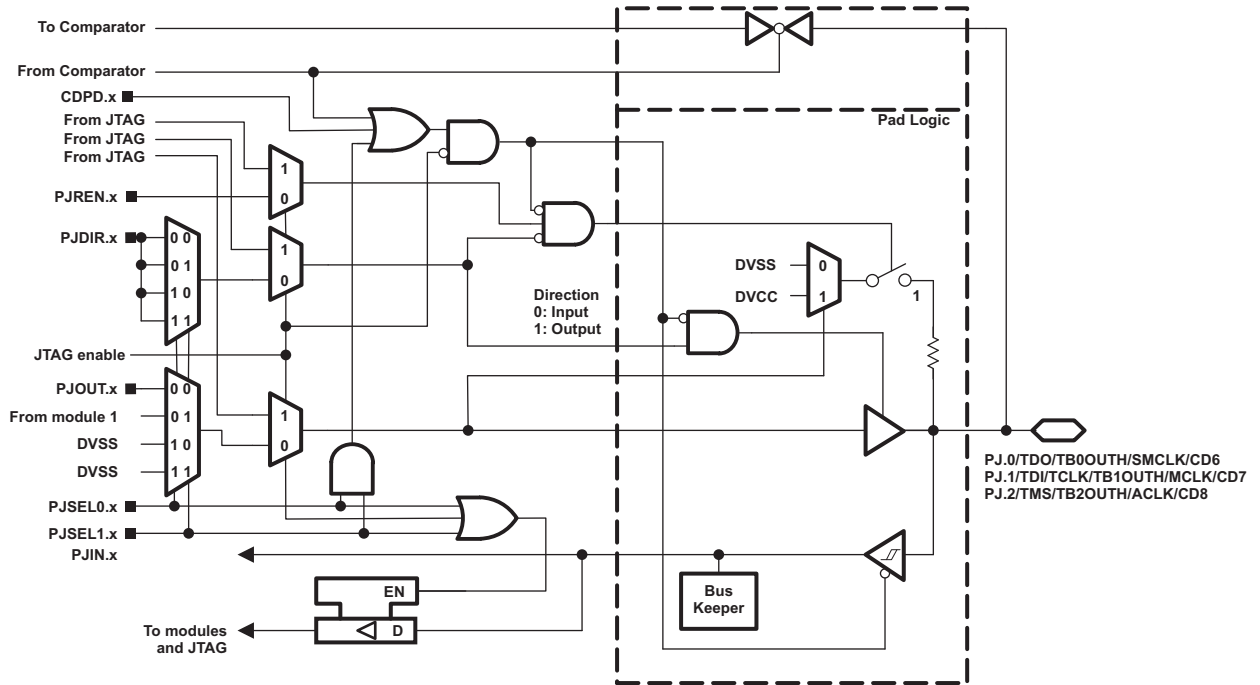

PRODUCT PREVIEW

Table 55. Port PJ (PJ.0 to PJ.3) Pin Functions

PIN NAME (PJ.x)	x	FUNCTION	CONTROL BITS/ SIGNALS ⁽¹⁾		
			PJDIR.x	PJSEL1.x	PJSEL0.x
PJ.0/TDO/TB0OUTH/SMCLK/CD6	0	PJ.0 (I/O) ⁽²⁾	I: 0; O: 1	0	0
		TDO ⁽³⁾	X	X	X
		TB0OUTH	0	0	1
		SMCLK	1		
		CD6	X	1	1
PJ.1/TDI/TCLK/TB1OUTH/MCLK/CD7	1	PJ.1 (I/O) ⁽²⁾	I: 0; O: 1	0	0
		TDI/TCLK ^{(3) (4)}	X	X	X
		TB1OUTH	0	0	1
		MCLK	1		
		CD7	X	1	1
PJ.2/TMS/TB2OUTH/ACLK/CD8	2	PJ.2 (I/O) ⁽²⁾	I: 0; O: 1	0	0
		TMS ^{(3) (4)}	X	X	X
		TB2OUTH	0	0	1
		ACLK	1		
		CD8	X	1	1
PJ.3/TCK/CD9	3	PJ.3 (I/O) ⁽²⁾	I: 0; O: 1	0	0
		TCK ^{(3) (4)}	X	X	X
		CD9	X	1	1

(1) X = Don't care

(2) Default condition

(3) The pin direction is controlled by the JTAG module. JTAG mode selection is made via the SYS module or by the SpyBiWire four wire entry sequence. PJSEL1.x and PJSEL0.x have no effect in these cases.

(4) In JTAG mode, pullups are activated automatically on TMS, TCK, and TDI/TCLK. PJREN.x are do not care.

PACKAGING INFORMATION

Orderable Device	Status ⁽¹⁾	Package Type	Package Drawing	Pins	Package Qty	Eco Plan ⁽²⁾	Lead/ Ball Finish	MSL Peak Temp ⁽³⁾	Samples (Requires Login)
MSP430FR5720IRGER	PREVIEW	VQFN	RGE	24	3000	TBD	Call TI	Call TI	
MSP430FR5720IRGET	PREVIEW	VQFN	RGE	24	250	TBD	Call TI	Call TI	
MSP430FR5725IRHAR	ACTIVE	VQFN	RHA	40	2500	Green (RoHS & no Sb/Br)	CU NIPDAU	Level-3-260C-168 HR	
MSP430FR5725IRHAT	PREVIEW	VQFN	RHA	40	250	TBD	Call TI	Call TI	
MSP430FR5728IRGER	ACTIVE	VQFN	RGE	24	3000	Green (RoHS & no Sb/Br)	CU NIPDAU	Level-2-260C-1 YEAR	
MSP430FR5728IRGET	PREVIEW	VQFN	RGE	24	250	TBD	Call TI	Call TI	
MSP430FR5729IDA	PREVIEW	TSSOP	DA	38	40	TBD	Call TI	Call TI	
MSP430FR5729IDAR	ACTIVE	TSSOP	DA	38	2000	Green (RoHS & no Sb/Br)	CU NIPDAU	Level-2-260C-1 YEAR	
MSP430FR5729IRHAR	ACTIVE	VQFN	RHA	40	2500	Green (RoHS & no Sb/Br)	CU NIPDAU	Level-3-260C-168 HR	
MSP430FR5729IRHAT	PREVIEW	VQFN	RHA	40	250	TBD	Call TI	Call TI	
MSP430FR5730IRGER	ACTIVE	VQFN	RGE	24	3000	Green (RoHS & no Sb/Br)	CU NIPDAU	Level-2-260C-1 YEAR	
MSP430FR5730IRGET	PREVIEW	VQFN	RGE	24	250	TBD	Call TI	Call TI	
MSP430FR5735IRHAR	ACTIVE	VQFN	RHA	40	2500	Green (RoHS & no Sb/Br)	CU NIPDAU	Level-3-260C-168 HR	
MSP430FR5735IRHAT	PREVIEW	VQFN	RHA	40	250	TBD	Call TI	Call TI	
MSP430FR5738IRGER	ACTIVE	VQFN	RGE	24	3000	Green (RoHS & no Sb/Br)	CU NIPDAU	Level-2-260C-1 YEAR	
MSP430FR5738IRGET	PREVIEW	VQFN	RGE	24	250	TBD	Call TI	Call TI	
MSP430FR5739IDA	PREVIEW	TSSOP	DA	38	40	TBD	Call TI	Call TI	
MSP430FR5739IDAR	ACTIVE	TSSOP	DA	38	2000	Green (RoHS & no Sb/Br)	CU NIPDAU	Level-2-260C-1 YEAR	
MSP430FR5739IRHA	PREVIEW	VQFN	RHA	40	1	TBD	Call TI	Call TI	
MSP430FR5739IRHAR	ACTIVE	VQFN	RHA	40	2500	Green (RoHS & no Sb/Br)	CU NIPDAU	Level-3-260C-168 HR	
MSP430FR5739IRHAT	PREVIEW	VQFN	RHA	40	250	TBD	Call TI	Call TI	
XMS430FR5739IRHAR	ACTIVE	VQFN	RHA	40	1	TBD	Call TI	Call TI	

⁽¹⁾ The marketing status values are defined as follows:

ACTIVE: Product device recommended for new designs.

LIFEBUY: TI has announced that the device will be discontinued, and a lifetime-buy period is in effect.

NRND: Not recommended for new designs. Device is in production to support existing customers, but TI does not recommend using this part in a new design.

PREVIEW: Device has been announced but is not in production. Samples may or may not be available.

OBSOLETE: TI has discontinued the production of the device.

⁽²⁾ Eco Plan - The planned eco-friendly classification: Pb-Free (RoHS), Pb-Free (RoHS Exempt), or Green (RoHS & no Sb/Br) - please check <http://www.ti.com/productcontent> for the latest availability information and additional product content details.

TBD: The Pb-Free/Green conversion plan has not been defined.

Pb-Free (RoHS): TI's terms "Lead-Free" or "Pb-Free" mean semiconductor products that are compatible with the current RoHS requirements for all 6 substances, including the requirement that lead not exceed 0.1% by weight in homogeneous materials. Where designed to be soldered at high temperatures, TI Pb-Free products are suitable for use in specified lead-free processes.

Pb-Free (RoHS Exempt): This component has a RoHS exemption for either 1) lead-based flip-chip solder bumps used between the die and package, or 2) lead-based die adhesive used between the die and leadframe. The component is otherwise considered Pb-Free (RoHS compatible) as defined above.

Green (RoHS & no Sb/Br): TI defines "Green" to mean Pb-Free (RoHS compatible), and free of Bromine (Br) and Antimony (Sb) based flame retardants (Br or Sb do not exceed 0.1% by weight in homogeneous material)

⁽³⁾ MSL, Peak Temp. -- The Moisture Sensitivity Level rating according to the JEDEC industry standard classifications, and peak solder temperature.

Important Information and Disclaimer: The information provided on this page represents TI's knowledge and belief as of the date that it is provided. TI bases its knowledge and belief on information provided by third parties, and makes no representation or warranty as to the accuracy of such information. Efforts are underway to better integrate information from third parties. TI has taken and continues to take reasonable steps to provide representative and accurate information but may not have conducted destructive testing or chemical analysis on incoming materials and chemicals. TI and TI suppliers consider certain information to be proprietary, and thus CAS numbers and other limited information may not be available for release.

In no event shall TI's liability arising out of such information exceed the total purchase price of the TI part(s) at issue in this document sold by TI to Customer on an annual basis.

RGE (S-PVQFN-N24)

PLASTIC QUAD FLATPACK NO-LEAD

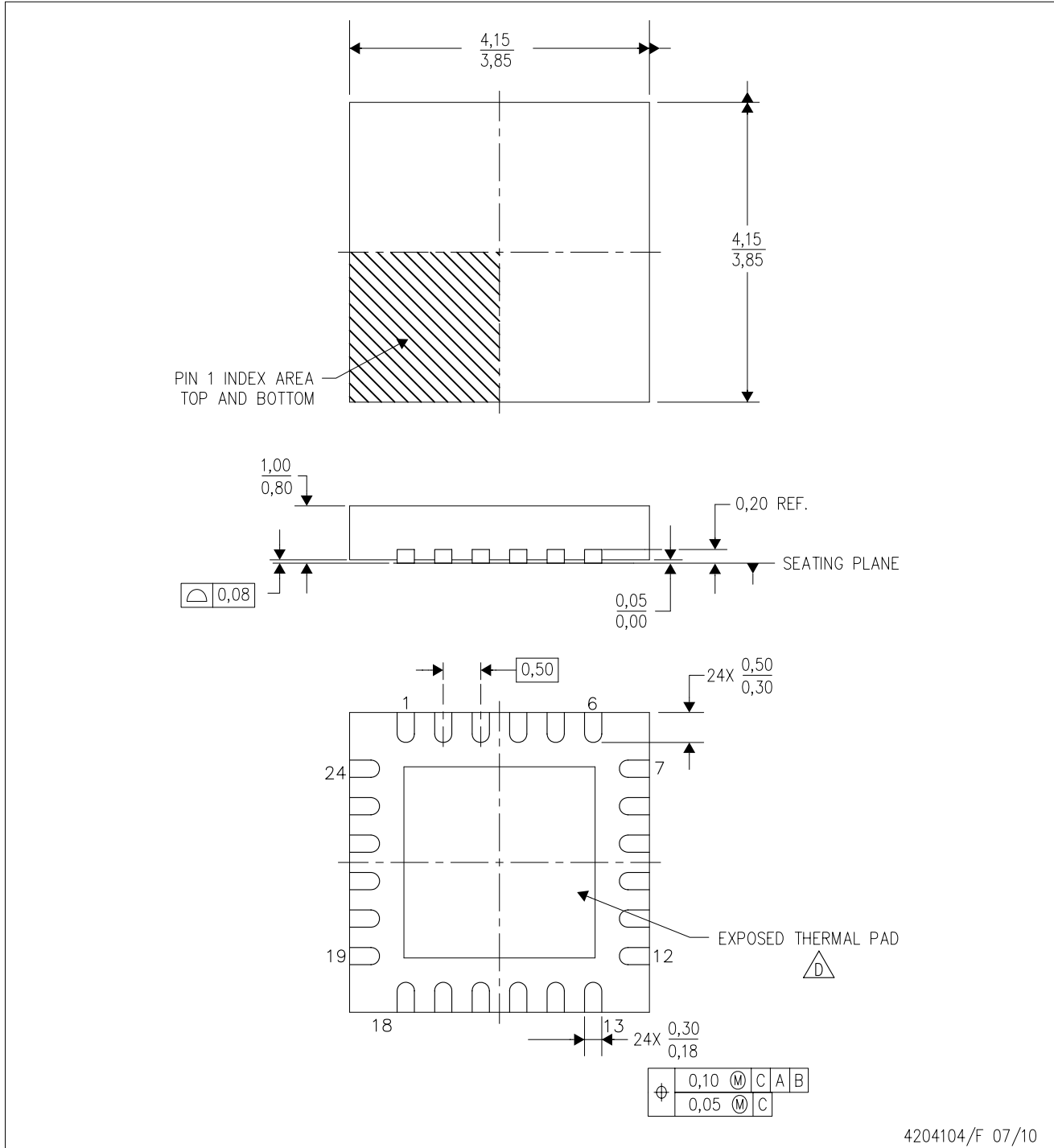

4204104/F 07/10

- NOTES:
- A. All linear dimensions are in millimeters. Dimensioning and tolerancing per ASME Y14.5M-1994.
 - B. This drawing is subject to change without notice.
 - C. Quad Flatpack, No-Leads (QFN) package configuration.
 -  The package thermal pad must be soldered to the board for thermal and mechanical performance. See the Product Data Sheet for details regarding the exposed thermal pad dimensions.
 - E. Falls within JEDEC MO-220.

THERMAL PAD MECHANICAL DATA

RGE (S-PVQFN-N24)

PLASTIC QUAD FLATPACK NO-LEAD

THERMAL INFORMATION

This package incorporates an exposed thermal pad that is designed to be attached directly to an external heatsink. The thermal pad must be soldered directly to the printed circuit board (PCB). After soldering, the PCB can be used as a heatsink. In addition, through the use of thermal vias, the thermal pad can be attached directly to the appropriate copper plane shown in the electrical schematic for the device, or alternatively, can be attached to a special heatsink structure designed into the PCB. This design optimizes the heat transfer from the integrated circuit (IC).

For information on the Quad Flatpack No-Lead (QFN) package and its advantages, refer to Application Report, QFN/SON PCB Attachment, Texas Instruments Literature No. SLUA271. This document is available at www.ti.com.

The exposed thermal pad dimensions for this package are shown in the following illustration.

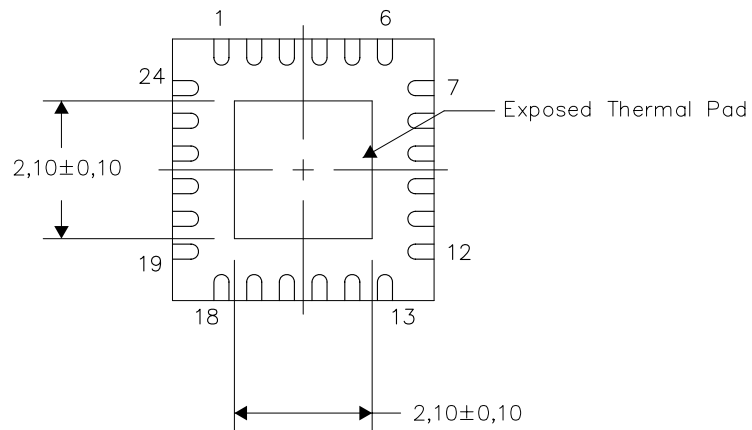

Bottom View

Exposed Thermal Pad Dimensions

4206344-6/X 03/11

NOTES: A. All linear dimensions are in millimeters

RHA (S-PVQFN-N40)

PLASTIC QUAD FLATPACK NO-LEAD

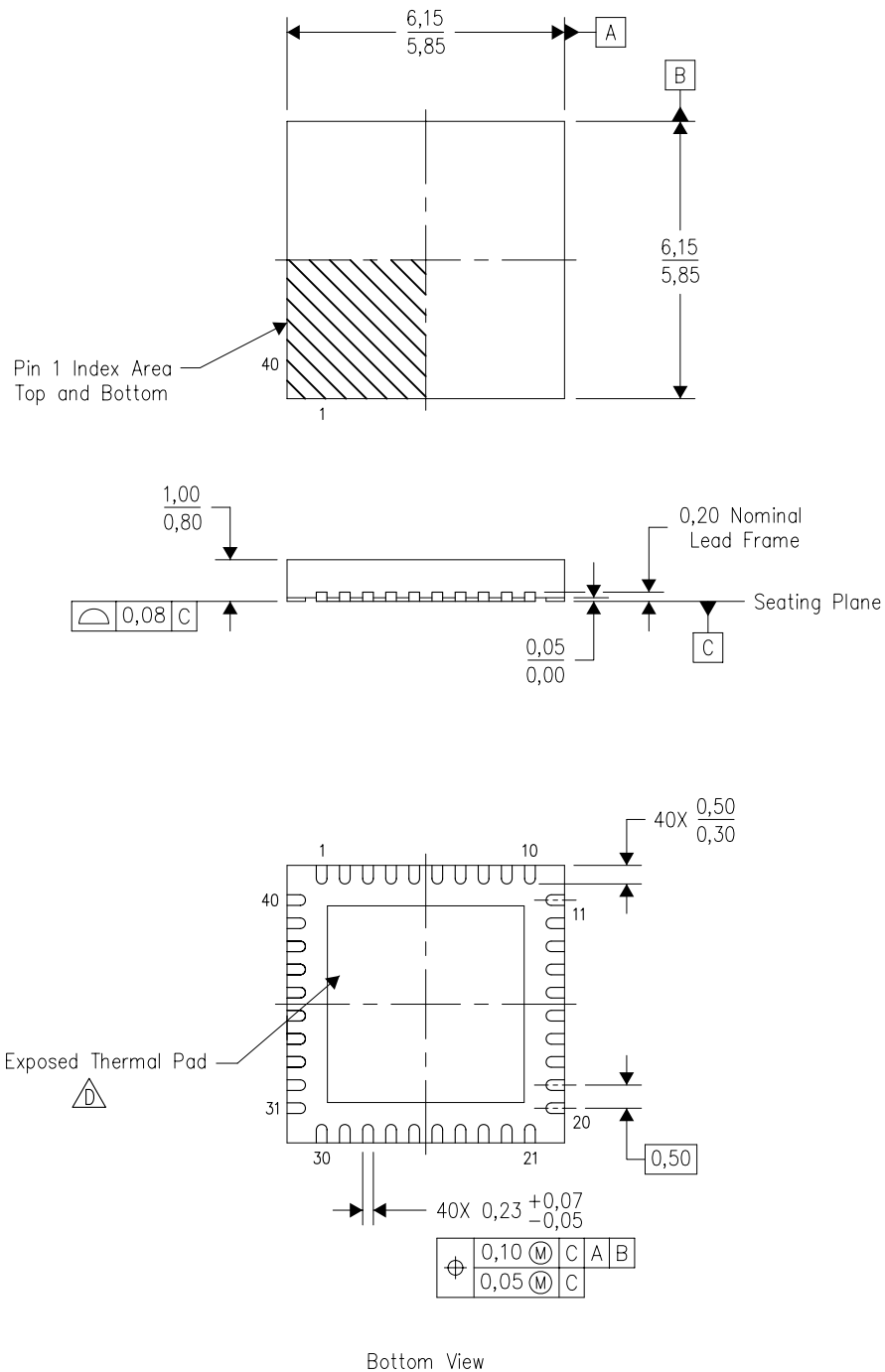

4204276/D 08/10

- NOTES:
- A. All linear dimensions are in millimeters. Dimensioning and tolerancing per ASME Y14.5M-1994.
 - B. This drawing is subject to change without notice.
 - C. QFN (Quad Flatpack No-Lead) Package configuration.
 -  The package thermal pad must be soldered to the board for thermal and mechanical performance. See the Product Data Sheet for details regarding the exposed thermal pad dimensions.
 - E. Package complies to JEDEC MO-220 variation VJJD-2.

THERMAL PAD MECHANICAL DATA

RHA (S-PVQFN-N40)

PLASTIC QUAD FLATPACK NO-LEAD

THERMAL INFORMATION

This package incorporates an exposed thermal pad that is designed to be attached directly to an external heatsink. The thermal pad must be soldered directly to the printed circuit board (PCB). After soldering, the PCB can be used as a heatsink. In addition, through the use of thermal vias, the thermal pad can be attached directly to the appropriate copper plane shown in the electrical schematic for the device, or alternatively, can be attached to a special heatsink structure designed into the PCB. This design optimizes the heat transfer from the

For information on the Quad Flatpack No-Lead (QFN) package and its advantages, refer to Application Report, QFN/SON PCB Attachment, Texas Instruments Literature No. SLUA271. This document is available at www.ti.com.

The exposed thermal pad dimensions for this package are shown in the following illustration.

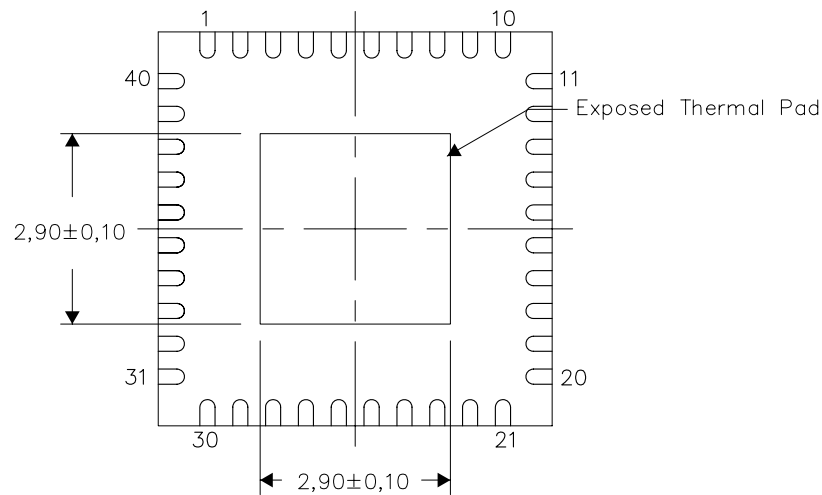

Bottom View

Exposed Thermal Pad Dimensions

4206355-3/N 03/11

NOTES: A. All linear dimensions are in millimeters

RHA (S-PVQFN-N40)

PLASTIC QUAD FLATPACK NO-LEAD

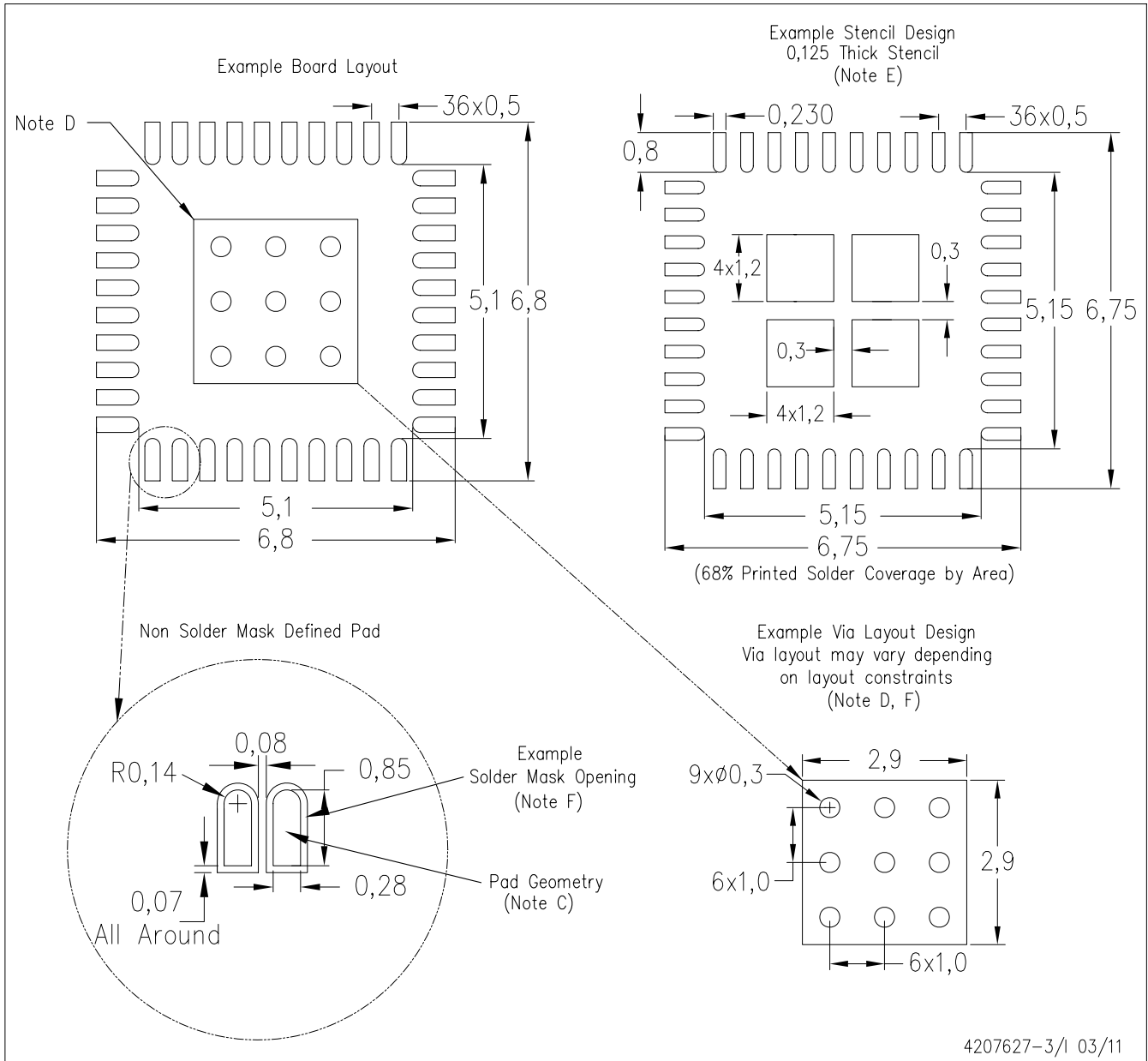

- NOTES:
- A. All linear dimensions are in millimeters.
 - B. This drawing is subject to change without notice.
 - C. Publication IPC-7351 is recommended for alternate designs.
 - D. This package is designed to be soldered to a thermal pad on the board. Refer to Application Note, Quad Flat-Pack Packages, Texas Instruments Literature No. SLUA271, and also the Product Data Sheets for specific thermal information, via requirements, and recommended board layout. These documents are available at www.ti.com <<http://www.ti.com>>.
 - E. Laser cutting apertures with trapezoidal walls and also rounding corners will offer better paste release. Customers should contact their board assembly site for stencil design recommendations. Refer to IPC 7525 for stencil design considerations.
 - F. Customers should contact their board fabrication site for recommended solder mask tolerances and via tenting recommendations for vias placed in the thermal pad.

DA (R-PDSO-G**)
 38 PIN SHOWN

PLASTIC SMALL-OUTLINE PACKAGE



- NOTES:
- A. All linear dimensions are in millimeters.
 - B. This drawing is subject to change without notice.
 - C. Body dimensions do not include mold flash or protrusion. Mold flash and protrusion shall not exceed 0.15 per side.
 - Falls within JEDEC MO-153, except 30 pin body length.

DA (R-PDSO-G38)

PLASTIC SMALL OUTLINE



- NOTES:
- A. All linear dimensions are in millimeters.
 - B. This drawing is subject to change without notice.
 - C. Laser cutting apertures with trapezoidal walls and also rounding corners will offer better paste release. Customers should contact their board assembly site for stencil design recommendations. Example stencil design based on a 50% volumetric metal load solder paste. Refer to IPC-7525 for other stencil recommendations.
 - D. Contact the board fabrication site for recommended soldermask tolerances.

IMPORTANT NOTICE

Texas Instruments Incorporated and its subsidiaries (TI) reserve the right to make corrections, modifications, enhancements, improvements, and other changes to its products and services at any time and to discontinue any product or service without notice. Customers should obtain the latest relevant information before placing orders and should verify that such information is current and complete. All products are sold subject to TI's terms and conditions of sale supplied at the time of order acknowledgment.

TI warrants performance of its hardware products to the specifications applicable at the time of sale in accordance with TI's standard warranty. Testing and other quality control techniques are used to the extent TI deems necessary to support this warranty. Except where mandated by government requirements, testing of all parameters of each product is not necessarily performed.

TI assumes no liability for applications assistance or customer product design. Customers are responsible for their products and applications using TI components. To minimize the risks associated with customer products and applications, customers should provide adequate design and operating safeguards.

TI does not warrant or represent that any license, either express or implied, is granted under any TI patent right, copyright, mask work right, or other TI intellectual property right relating to any combination, machine, or process in which TI products or services are used. Information published by TI regarding third-party products or services does not constitute a license from TI to use such products or services or a warranty or endorsement thereof. Use of such information may require a license from a third party under the patents or other intellectual property of the third party, or a license from TI under the patents or other intellectual property of TI.

Reproduction of TI information in TI data books or data sheets is permissible only if reproduction is without alteration and is accompanied by all associated warranties, conditions, limitations, and notices. Reproduction of this information with alteration is an unfair and deceptive business practice. TI is not responsible or liable for such altered documentation. Information of third parties may be subject to additional restrictions.

Resale of TI products or services with statements different from or beyond the parameters stated by TI for that product or service voids all express and any implied warranties for the associated TI product or service and is an unfair and deceptive business practice. TI is not responsible or liable for any such statements.

TI products are not authorized for use in safety-critical applications (such as life support) where a failure of the TI product would reasonably be expected to cause severe personal injury or death, unless officers of the parties have executed an agreement specifically governing such use. Buyers represent that they have all necessary expertise in the safety and regulatory ramifications of their applications, and acknowledge and agree that they are solely responsible for all legal, regulatory and safety-related requirements concerning their products and any use of TI products in such safety-critical applications, notwithstanding any applications-related information or support that may be provided by TI. Further, Buyers must fully indemnify TI and its representatives against any damages arising out of the use of TI products in such safety-critical applications.

TI products are neither designed nor intended for use in military/aerospace applications or environments unless the TI products are specifically designated by TI as military-grade or "enhanced plastic." Only products designated by TI as military-grade meet military specifications. Buyers acknowledge and agree that any such use of TI products which TI has not designated as military-grade is solely at the Buyer's risk, and that they are solely responsible for compliance with all legal and regulatory requirements in connection with such use.

TI products are neither designed nor intended for use in automotive applications or environments unless the specific TI products are designated by TI as compliant with ISO/TS 16949 requirements. Buyers acknowledge and agree that, if they use any non-designated products in automotive applications, TI will not be responsible for any failure to meet such requirements.

Following are URLs where you can obtain information on other Texas Instruments products and application solutions:

Products

Audio	www.ti.com/audio
Amplifiers	amplifier.ti.com
Data Converters	dataconverter.ti.com
DLP® Products	www.dlp.com
DSP	dsp.ti.com
Clocks and Timers	www.ti.com/clocks
Interface	interface.ti.com
Logic	logic.ti.com
Power Mgmt	power.ti.com
Microcontrollers	microcontroller.ti.com
RFID	www.ti-rfid.com
RF/IF and ZigBee® Solutions	www.ti.com/lprf

Applications

Communications and Telecom	www.ti.com/communications
Computers and Peripherals	www.ti.com/computers
Consumer Electronics	www.ti.com/consumer-apps
Energy and Lighting	www.ti.com/energy
Industrial	www.ti.com/industrial
Medical	www.ti.com/medical
Security	www.ti.com/security
Space, Avionics and Defense	www.ti.com/space-avionics-defense
Transportation and Automotive	www.ti.com/automotive
Video and Imaging	www.ti.com/video
Wireless	www.ti.com/wireless-apps

TI E2E Community Home Page

e2e.ti.com

Mailing Address: Texas Instruments, Post Office Box 655303, Dallas, Texas 75265
Copyright © 2011, Texas Instruments Incorporated