

RE 13 \varnothing 13 mm, Precious Metal Brushes, 2.5 Watt, $\text{C}\epsilon$ approved

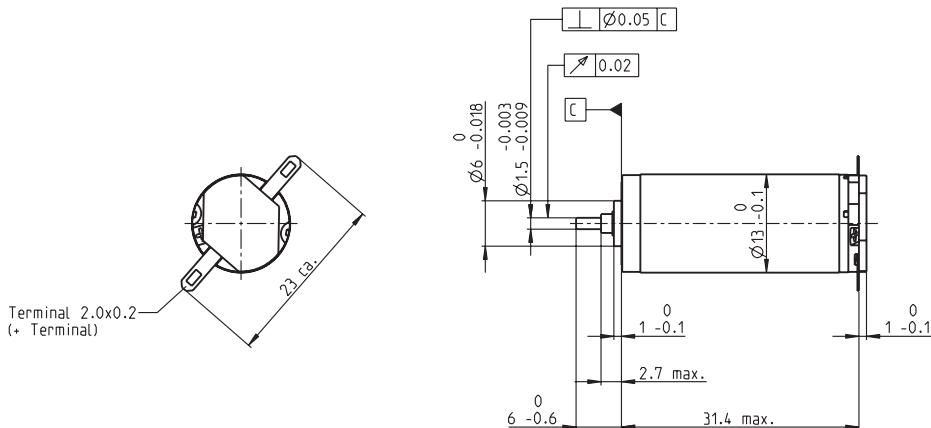

M 1:1

- Stock program
- Standard program
- Special program (on request)

Order Number

118461	118462	118463	118464	118465	118466	118467	118468	118469	118470	118471	118472	118473	118474	118475
--------	--------	--------	--------	--------	--------	--------	--------	--------	--------	--------	--------	--------	--------	--------

Motor Data

Values at nominal voltage		2.4	3.0	3.0	3.6	4.8	4.8	6.0	7.2	8.0	10.0	12.0	15.0	15.0	18.0	24.0	
1	Nominal voltage	V	2.4	3.0	3.0	3.6	4.8	4.8	6.0	7.2	8.0	10.0	12.0	15.0	15.0	18.0	24.0
2	No load speed	rpm	10500	12200	10700	10800	11400	10100	11400	11400	10900	11400	11000	11100	10300	10600	11500
3	No load current	mA	51.3	50.7	41.9	35.5	28.7	24.3	23.0	19.1	16.1	13.8	11.0	8.85	7.97	6.89	5.81
4	Nominal speed	rpm	8990	10300	8350	7930	7800	6390	7620	7700	7290	7760	7370	7460	6610	6910	7790
5	Nominal torque (max. continuous torque)	mNm	1.45	1.56	1.81	2.16	2.76	2.85	2.79	2.85	2.97	2.90	2.89	2.90	2.88	2.90	2.84
6	Nominal current (max. continuous current)	A	0.720	0.720	0.720	0.720	0.720	0.658	0.582	0.494	0.441	0.362	0.291	0.235	0.217	0.186	0.149
7	Stall torque	mNm	9.96	10.2	8.35	8.26	8.82	7.79	8.52	8.85	9.11	9.17	8.79	8.91	8.14	8.45	8.88
8	Starting current	A	4.63	4.42	3.15	2.63	2.22	1.74	1.72	1.48	1.31	1.11	0.856	0.699	0.592	0.526	0.451
9	Max. efficiency	%	80	80	79	78	79	78	79	79	79	79	79	79	78	79	79
Characteristics																	
10	Terminal resistance	Ω	0.519	0.679	0.951	1.37	2.16	2.75	3.50	4.85	6.11	9.03	14.0	21.5	25.3	34.2	53.2
11	Terminal inductance	mH	0.0213	0.0247	0.0323	0.0456	0.0727	0.092	0.114	0.164	0.223	0.316	0.485	0.749	0.870	1.19	1.79
12	Torque constant	mNm / A	2.15	2.32	2.65	3.15	3.97	4.47	4.97	5.96	6.95	8.28	10.3	12.7	13.7	16.1	19.7
13	Speed constant	rpm / V	4440	4120	3610	3040	2400	2140	1920	1600	1370	1150	930	749	695	595	485
14	Speed / torque gradient	rpm / mNm	1070	1210	1290	1320	1310	1320	1350	1300	1210	1260	1270	1260	1280	1270	1310
15	Mechanical time constant	ms	7.58	7.48	7.39	7.31	7.22	7.20	7.22	7.17	7.10	7.14	7.15	7.15	7.15	7.16	7.21
16	Rotor inertia	gcm ²	0.677	0.592	0.545	0.527	0.527	0.523	0.509	0.525	0.562	0.541	0.537	0.541	0.533	0.540	0.526

Specifications

- Thermal data**
- 17 Thermal resistance housing-ambient 33 K / W
 - 18 Thermal resistance winding-housing 7.0 K / W
 - 19 Thermal time constant winding 4.85 s
 - 20 Thermal time constant motor 346 s
 - 21 Ambient temperature -20 ... +65°C
 - 22 Max. permissible winding temperature +85°C
- Mechanical data (sleeve bearings)**
- 23 Max. permissible speed 19000 rpm
 - 24 Axial play 0.05 - 0.15 mm
 - 25 Radial play 0.014 mm
 - 26 Max. axial load (dynamic) 0.8 N
 - 27 Max. force for press fits (static) 15 N
 - 27 Max. force for press fits (static, shaft supported) 95 N
 - 28 Max. radial loading, 5 mm from flange 1.4 N
- Other specifications**
- 29 Number of pole pairs 1
 - 30 Number of commutator segments 7
 - 31 Weight of motor 21 g

Operating Range

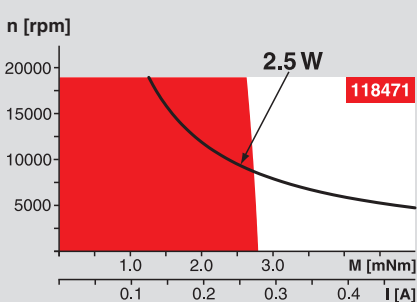

Comments

- Continuous operation**
In observation of above listed thermal resistance (lines 17 and 18) the maximum permissible winding temperature will be reached during continuous operation at 25°C ambient.
= Thermal limit.
- Short term operation**
The motor may be briefly overloaded (recurring).
- Assigned power rating**

maxon Modular System

Overview on page 16 - 21

Recommended Electronics:
LSC 30/2 Page 282
Notes 18