



Ledman Optoelectronic Co.,Ltd.

SPECIFICATIONS FOR LEDMAN HIGH POWER LED

Model No. : LPEH01RRWR1-MD0(01)

Document No. :

Revision No. :

Description:

- 1W High Power LED
- Colloid Color: Water Transparent
- Emission Color: Warm-White
- Viewing Angle :135°

Dice Material: InGaN

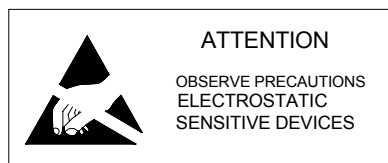

Add: Building 8,Block 2,Baimang Baiwangxin Industrial Park, Xili Area,Nanshan District,Shenzhen, P.R.China

Tel: 86-755-86139688

Fax: 86-755-86139001

Model No.:	LPEH01RRWR1-MD0(01)
Document No.:	
Revision No.:	

Outline Drawing

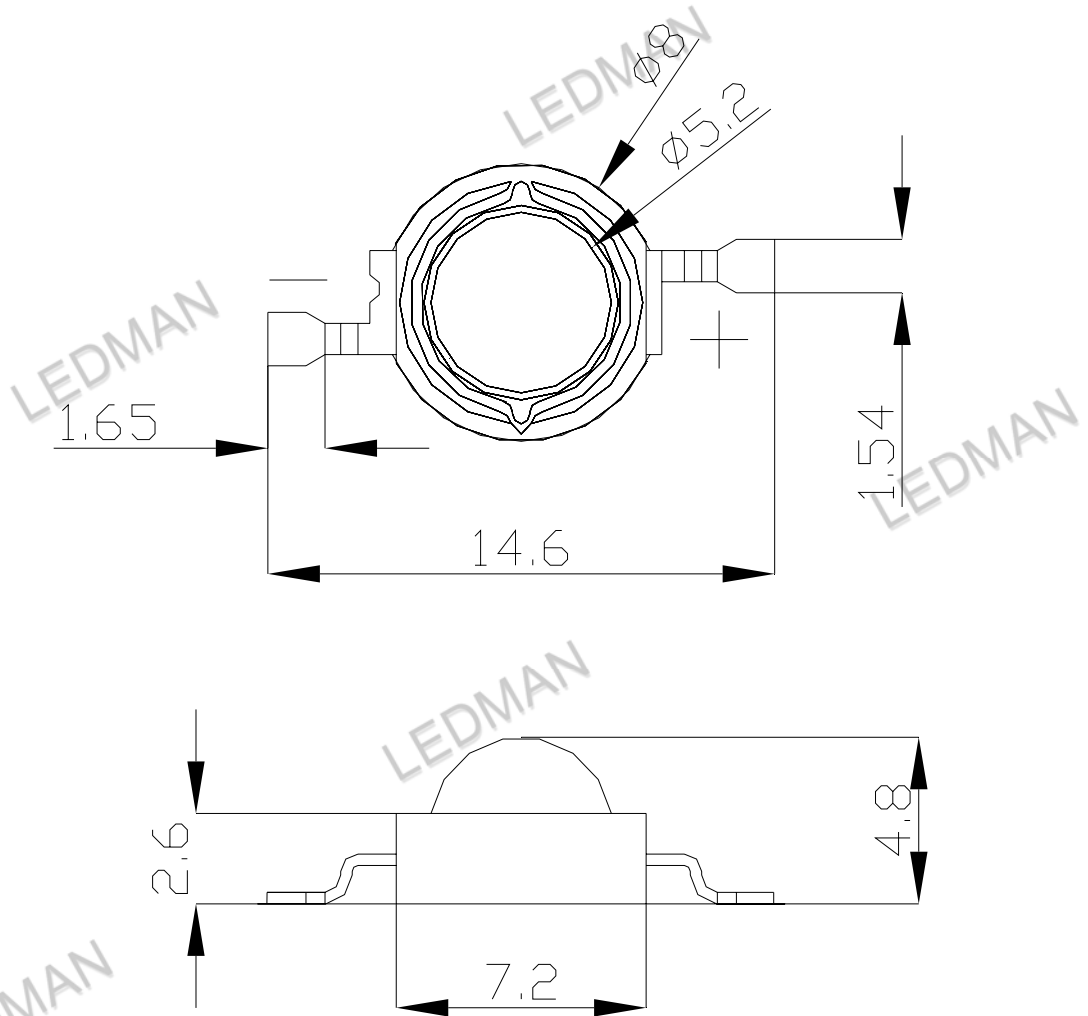

NOTES:

1. All dimensions area in mm tolerance is ± 0.25 mm unless otherwise noted.
2. Electrically-isolated thermal paths.



Model No.:	LPEH01RRWR1-MD0(01)
Document No.:	
Revision No.:	

Applications:

1	Signal lighting backlighting
2	Flashlight Headlight
3	Decorative entertainment and landscape lighting
4	Signage and channel letter

Absolute Maximum Ratings ($T_a = 25^\circ\text{C}$)

Items	Symbol	Absolute maximum Rating	Unit
DC Forward Current	I_F	350	mA
Peak Forward Current*	I_{FP}	1000	mA
Reverse Voltage	V_R	5	V
Power Dissipation	P_D	1120	mW
Operation Temperature	T_{opr}	-30 ~ +110	$^\circ\text{C}$
Storage Temperature	T_{stg}	-40 ~ +120	$^\circ\text{C}$

*pulse width $\leq 0.1\text{msec}$ duty $\leq 1/10$

Typical Electrical & Optical Characteristics ($T_a = 25^\circ\text{C}$)

Items	Symbol	Condition	Min.	Typ.	Max.	Unit
Forward Voltage	V_F	$I_F = 350\text{mA}$	---	3.2		V
Reverse Current	I_R	$V_R = 5\text{V}$	---	---	10	μA
Color Temperature	CCT	$I_F = 350\text{mA}$	---	3200	---	K
Chromaticity Coordinates	X	$I_F = 350\text{mA}$	---	0.4280	---	---
	Y	$I_F = 350\text{mA}$	---	0.4090	---	---
Luminous Flux	Φ_v	$I_F = 350\text{mA}$	---	95	---	lm
50% Power Angle	$2\theta_{1/2}$	$I_F = 350\text{mA}$	---	135	---	deg
Thermal Resistance (Junction to Board)	R_{J-B}	$I_F = 350\text{mA}$	---	8	---	$^\circ\text{C/W}$

Important Notes:

- 1) All ranks will be included per delivery, rank ratio will be determined by Ledman.
- 2) Tolerance of measurement of V_F is $\pm 0.1\text{ V}$.
- 3) Tolerance of measurement of the color coordinates X,Y is ± 0.015 .
- 4) Tolerance of measurement of luminous intensity is $\pm 15\%$.
- 5) For Reliability test conditions and data, Please refer to "**Reliability Test**" section on page 6
- 6) For how to use Ledman LED product safely, Please refer to "**Application Notes**" section on page 8 to 10.
- 7) Packaging methods are available to be chosen from, please refer to "**packaging**" section on page 11.
- 8) As we are making continuous efforts to improve the performance of LED, Specifications are subject to change without notice.
- 9) Information is tentative and subject to change without notice.

CIE Chromaticity Diagram

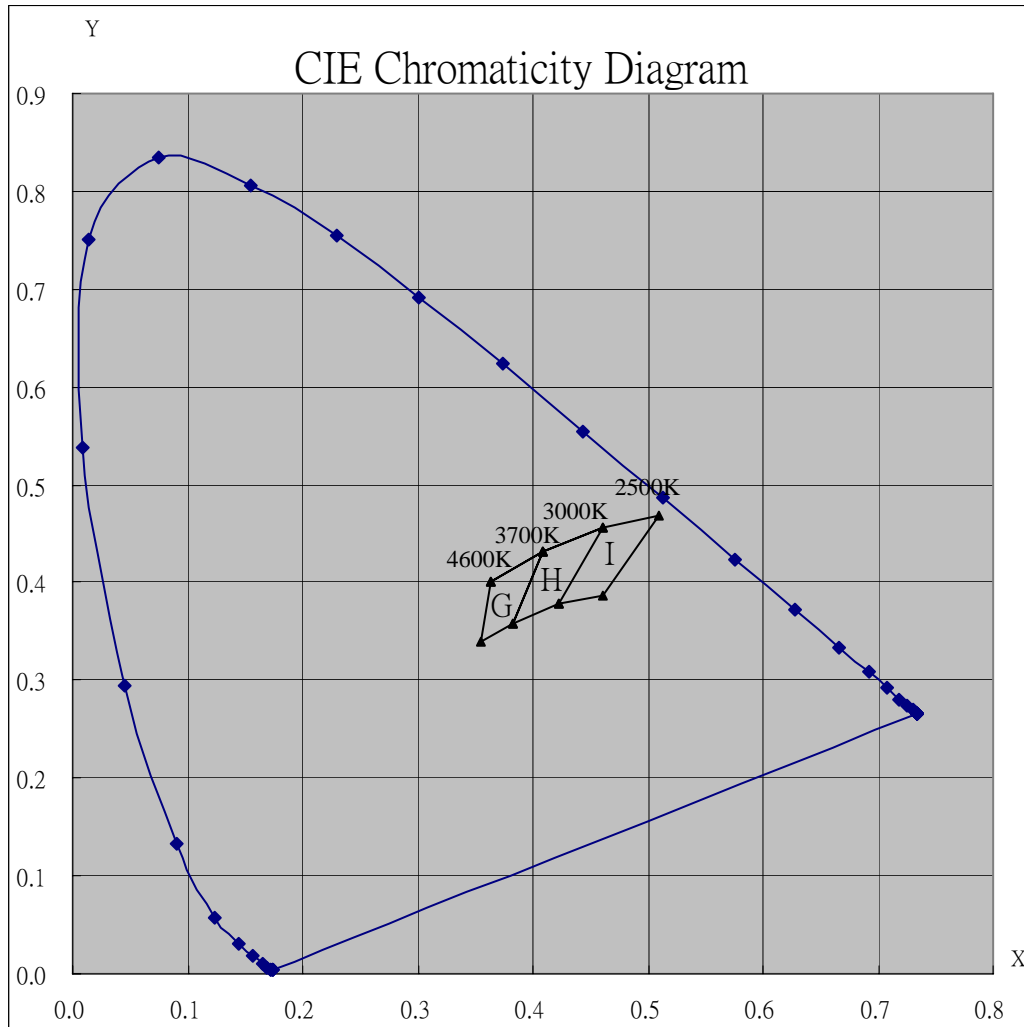

Color Ranks(IF=350mA,Ta=25°C)

Color Ranks		CIE				CCT
G	X	0.3638	0.4087	0.3820	0.3540	3700K-4600K
	Y	0.4001	0.4322	0.3580	0.3400	
H	X	0.4087	0.4608	0.4226	0.3820	3000K-3700K
	Y	0.4322	0.4570	0.3775	0.3580	
I	X	0.4608	0.5090	0.4600	0.4226	2500K-3000K
	Y	0.4570	0.4689	0.3864	0.3775	

Measurement uncertainty of the color coordinates:±0.015

Typical Optical-Electronic Characteristic Curves:

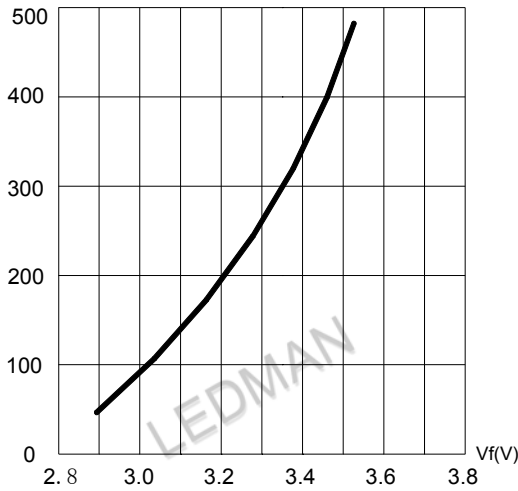

Fig.1 Forward Current vs. Forward Voltage

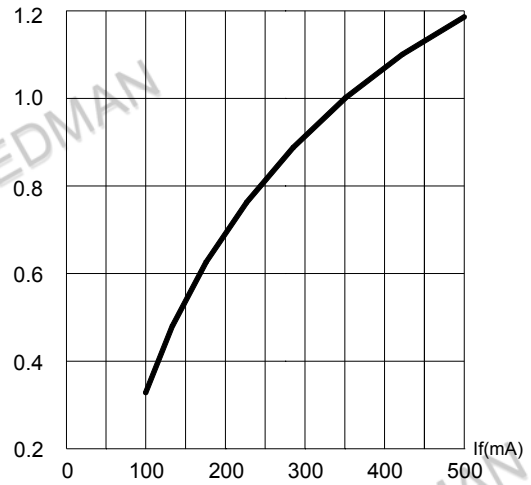

Fig.2 Relative Luminous Intensity vs. Forward Current
CCT=3200 le(%)

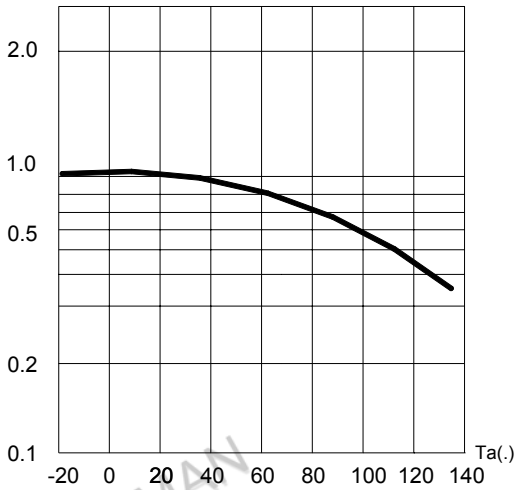

Fig.3 Relative Luminous Intensity vs. Ambient Temperature

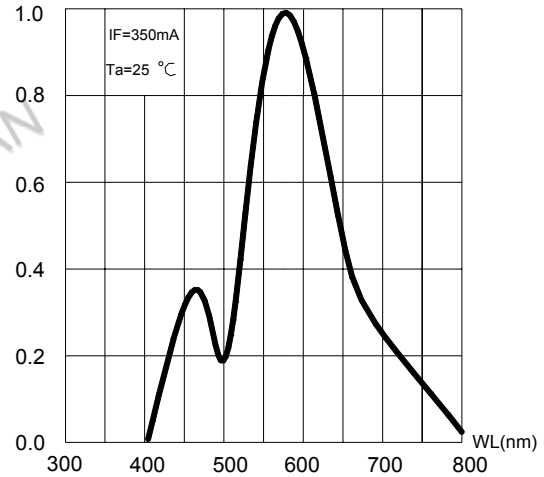

Fig.4 Relative Luminous Flux vs. Wavelength

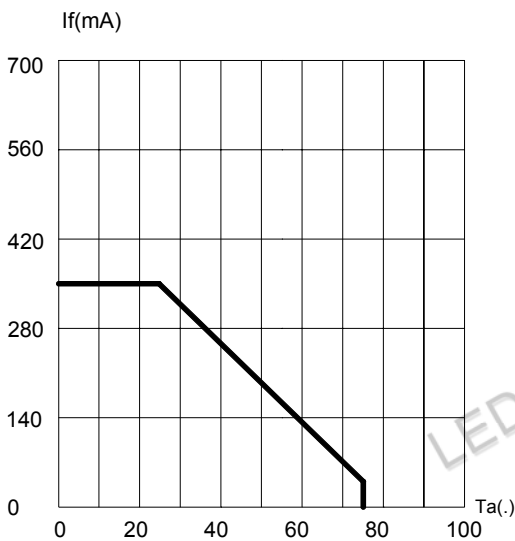

Fig.5 Maximum Forward Current vs. Ambient Temperature

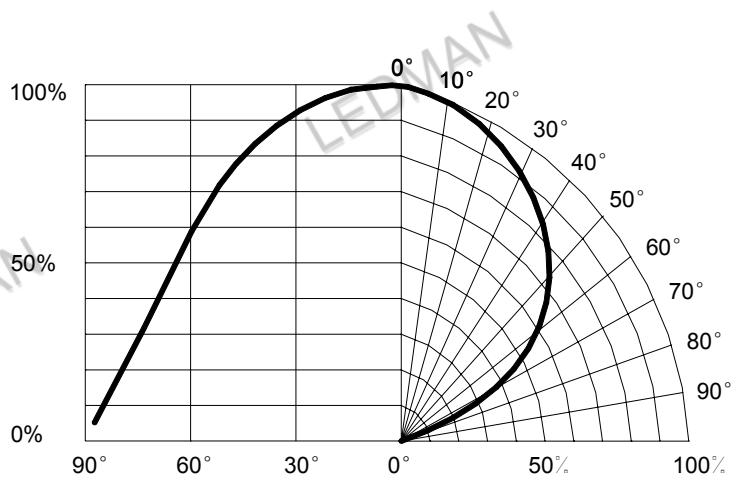

Fig.6 Relative Luminous Intensity vs. Radiation Angle



Reliability Test Standards

Test item:

Type	Test item	Applicable standard	Test condition	Duration	Sampling number	Accept criteria
environment test	Temperature cycles	JEITA ED-4701 100 105	-40°C ~ 25°C ~ 100°C ~ 25°C 30min 5min 30min 5min	100cycles	30	0/30
	Thermal shock	MIL-STD-202G	-40°C ~ 100°C 15min 15min	300cycles	30	0/30
	High humidity heat cycles	JEITA ED-4701 200 203	30°C ~ 65°C RH=90% 24hrs/1 cycle	50cycles	30	0/30
	High temperature storage	JEITA ED-4701 200 201	T _a =100°C	1000hrs	30	0/30
	Low temperature storage	JEITA ED-4701 200 202	T _a =-40°C	1000hrs	30	0/30
	High temperature & high humidity storage	JEITA ED-4701 100 103	T _a =60°C RH=90%	1000hrs	30	0/30
life test	Normal temperature life test	/	T _a =25°C I _F =350mA	1000hrs	30	0/30
	High temperature & high humidity life test	/	T _a =60°C RH=90% I _F =250mA	1000hrs	30	0/30
	Low temperature life test	/	T _a =-30°C I _F =300mA	1000hrs	30	0/30
destructive experiment	Resistance to soldering heat	JEITA ED-4701 300 301	T _{sol} =260°C±5°C, 10sec	one time	5	0/30
	Solderability	/	T _{sol} =245°C±5°C, 5sec using flux	one time	5	0/30
physical experiment	Vibration	JEITA ED-4701 400 403	20G 20-2000HZ 4mins X,Y,Z 3directions	each 4cycles	5	0/30
	Drop	/	75CM	3 times	5	0/30

Failure Criteria:

Item	Symbol	Test condition	Criteria for Judgment
Forward Voltage	V _F	I _F =350mA	Initial Data±10%
Reverse Current	I _R	V _R =5V	≦ 10μA
Luminous flux	φ _V	I _F =350mA	Single led degradation ≦ 50% and Average degradation ≦ 30%
Solderability			Over 95%
Vibration		I _F =350mA	No dead lamps or visual damage
Drop		I _F =350mA	No dead lamps or visual damage

Remark: RH:Environment humidity; T_a:Environment temperature;
T_{sol}:Tin temperature; I_F:Forward current; V_R:Reverse voltage.



Model No.:	LPEH01RRWR1-MD0(01)
Document No.:	
Revision No.:	

High Power LED Product Naming Rule

L P X XXX XX XX X — X XX

1 23 1 2

9 Serial number of product creation

8 50% Power Angle (2θ 1/2)

C0: 120°

D0: 135°

7 the shape of lens

L: Lambertian

M: Molding

T: Top viewing

6 Power Dissipation

0: 0.5W

1: 1W

3: 3W

5 Emitted color distinguishing

YL: Yellow

HR: Red

PG: Green

BL: Blue

WW: white

WR: warm white

4 Chip, code-named

1: The manufacturer code

2: The size code

3 Bracket, code-named

1: The manufacturer code

23: Serial number

2 The substrate appearance shape

E: Without substrate

S: Star

R: Round

F: Quadrate

1 Product Type

P: High-Power LED

Ledman code



Model No.:	LPEH01RRWR1-MD0(01)
Document No.:	
Revision No.:	

Application Notes

Storage

1. Before opening the package, the LEDs should be kept under the condition $< 30^{\circ}\text{C}$ and $< 90\% \text{RH}$. After opening the package, the LEDs should be stored under the condition $< 30^{\circ}\text{C}$ and $< 70\% \text{RH}$.
2. The LEDs should be used within a year. And after opening the package, The LEDs should be used within 168 hours (7 days).
3. If the desiccant is faded or the LEDs have exceeded the storage time, Re-baking is required under the condition $60 \pm 6^{\circ}\text{C}$ for 24 hours.
4. The lens of LEDs is prone to attract dust so the relevant steps should be taken to keep the emitter free of dust.

Handling

Handle the component along the side surfaces by using forceps or appropriate tools. The forceps or other appropriate tools should not put any pressure on the lens, it's also strictly forbidden to poke and press the lens.

Thermal Management

When the LED is driven by large current, the T_J (junction temperature) will exceed its limit, which will shorten the lifetime of LEDs seriously. The thermal management should effectively reduce the thermal resistance of products.

The general way for the thermal management is to mount the LED on a metal core printed circuit board (MCPCB). It is recommended that the surface area of the MCPCB is at least 20 cm^2 for 1W LED (and 50 cm^2 for 3W LED), while we recommend using an additional heat sink, and the MCPCB heat-conducting adhesive with a thermal conductivity greater than 3.0 W/mK . The thermal glue or paste should have a thermal conductivity greater than 3.0 W/mK and its thickness must be less than $100 \mu\text{m}$.

Soldering/Reflow Soldering

1. Soldering Iron

It is recommended to solder by soldering iron with the soldering iron tip temperature less than 350°C and with the time less than 3 seconds. The power of soldering iron should be less than 60W. After finishing one lead soldering, wait 2 seconds or more for another lead soldering.

Do not press the lens while soldering, the problems often start at the time of soldering, so be careful for the soldering.

2. Reflow Soldering Conditions

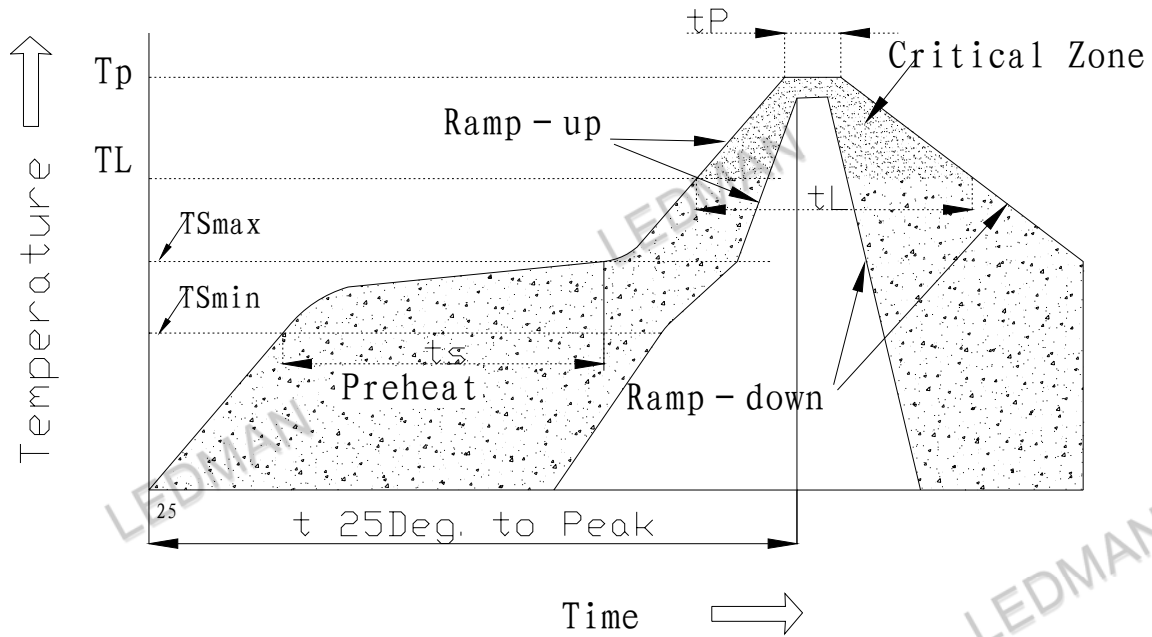
Table of Classification Reflow Profiles:

Profile Feature	Lead-Based Solder	Lead-Free Solder
Average ramp-up rate (TL to TP)	3°C/second max.	3°C/second max.
Preheat	60~120seconds	60~180seconds
-Temperature Min.(T _{Smin})	100°C	150°C
-Temperature Min.(T _{Smax})	130°C	200°C
T _{Smax} to TL		
-Ramp-up Rate	3°C/second	3°C/second
Time maintained above TL	160°C/60~150seconds	210°C/60~150seconds
Peak Temperature(TP)	220+0/-5°C	245+0/-5°C
Time within 5°C of Actual Peak Temperature(TP)	10 seconds	10 seconds
Ramp-down Rate	6°C/Seconds max.	6°C/Seconds max.
Time 25°C to Peak Temperature	6 minutes max.	8 minutes max.

Notes:

- (a) Reflow soldering should not be done more than two times.
- (b) While soldering, do not put stress on the LEDs during heating.
- (c) After soldering, do not warp the circuit board.

Cleaning

When cleaning is necessary, using the clean soft cloth and dipping the isopropyl alcohol to erase the dirt gently. Do not clean it with the solvents such as Acetone, lest erode or destroy the LEDs.



Model No.:	LPEH01RRWR1-MD0(01)
Document No.:	
Revision No.:	

Electrical Notes

1. The LED can not be driven reversely.
2. It's necessary to have the measures to limit the current Otherwise slight voltage shift may cause enormous current change and results in the failure of LEDs .
3. It is recommended that the drive current should be lower when the light output is enough for applying.It would be helpful to improve the product's reliability.

Antistatic

The LEDs are electrostatic sensitive devices,so antistatic steps should be taken during the processing.

Packaging Specifications of High Power

Tube packaging Specifications for Lambertian series products of high power:

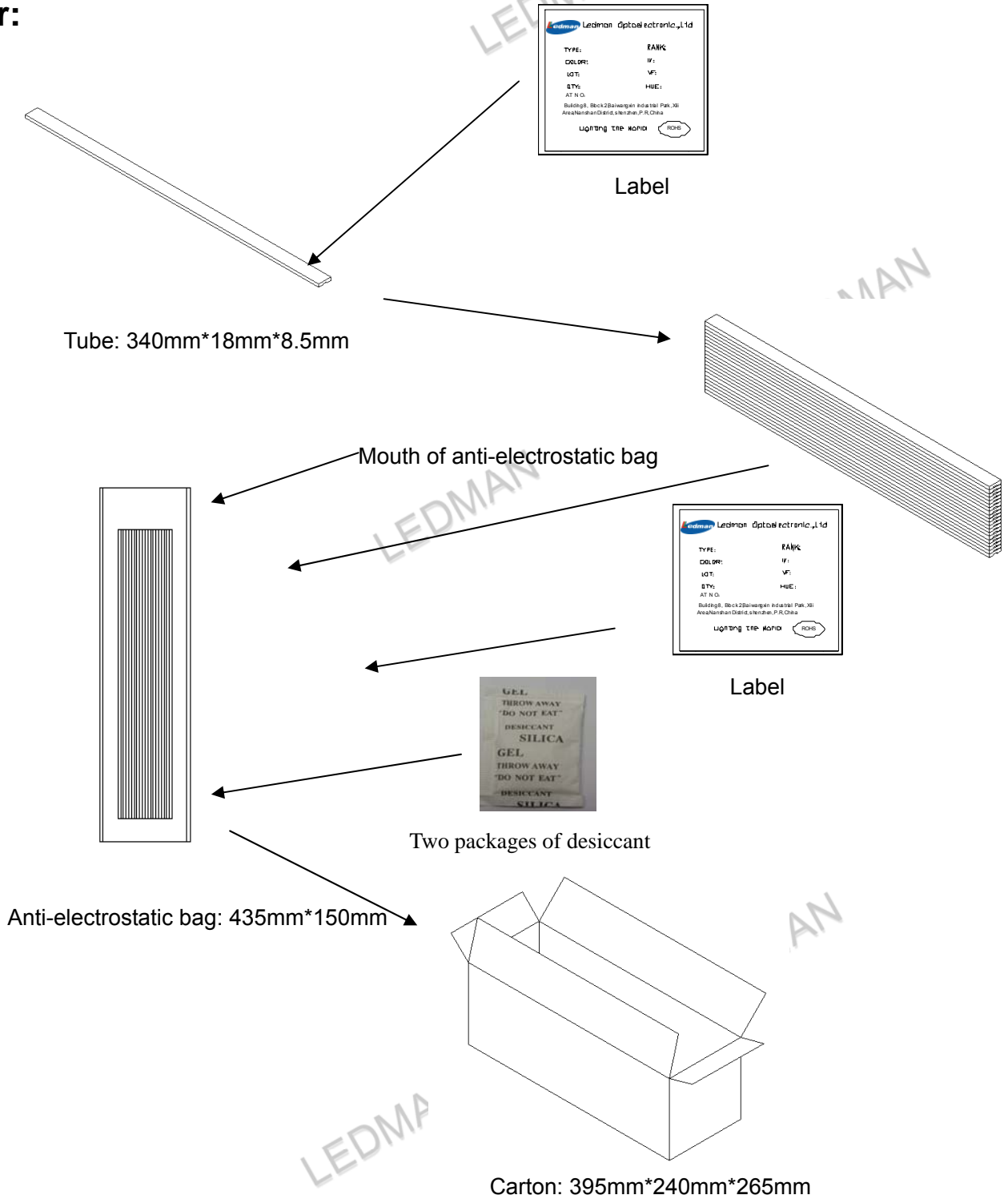

Type	Quantity per tube	Tubes per bag	Bags per carton	Quantity Total	Remark
Tube pack	40pcs	10	20	8000pcs	Lambertian series products of high power

Indication : We can use cardboard box to package ,only if there are enough products.